



## ECHOGRAPH 1095

Digital Ultrasonic Flaw Detector

Models  
1095 BASIC  
1095 DAC/TCG/AWS  
1095 DGS/DAC/TCG  
1095 DGS/DAC/TCG/AWS/JIS

# KARL DEUTSCH

# ECHOGRAPH 1095 – The New Generation of Manual Ultrasonic Testing



The convenient transport case provides space for extensive accessories

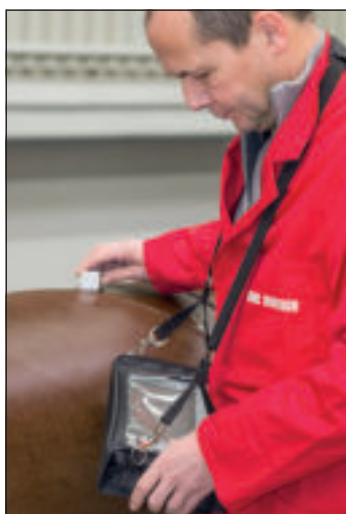

Mobile ultrasonic inspection with the ECHOGRAPH 1095 in the practical carrying case

## ECHOGRAPH 1095 –

### High-tech meets comfort: Ultrasonic Testing made simple

Besides the proven qualities of its predecessor model the new ultrasonic flaw detector ECHOGRAPH 1095 features time corrected gain and backwall echo attenuation. It is the ideal instrument for manual ultrasonic testing: digital, high-contrast and comfortable in practical applications. It is reliable and sturdy and thus can be used outdoors or in rough industry environment.

### The ECHOGRAPH 1095 ...

- is lightweight (only 2 kg) and easy to handle
- is equipped with a very large and high-contrast TFT colour display (7" diagonal, resolution 800 x 480 pix) with automatic brightness control and a large viewing angle
- guides the user safely and self-explanatorily through the applications by means of its plain text menu
- ensures extremely simple and complete adjustment with its user guidance
- supports the operator during probe handling and instrument adjustment (DAC, TCG, AWS, DGS, JIS, ...)
- offers direct access to all important key functions
- displays up to 6 measured values in large digits
- is equipped with 3 monitors to measure amplitude and time-of-flight, as well as 3 associated control lamps on the front panel for monitoring threshold values
- enables to show reference echoes and to record echo dynamics
- enables simple freezing and storing of A-scans
- allows to move all 3 monitor gates in "freeze" mode and recalculates the displayed measured values accordingly
- comes with a convenient text editor which enables the storage of each data set with an individual file name
- contains a probe data base for easy entering of probe data, even for third-party probes
- displays all functions in plain text on the screen, in addition to the 6 function keys
- permits selection of the pulse repetition frequency (PRF) from 10 Hz up to 5000 Hz: low PRF to avoid ghost echoes, and high PRF for high testing speed in case of automated testing
- saves all data, e.g. screenshots as BMP files or series of measurements as CSV files, on a removable 8 GB SD flash card
- evaluates the time-of-flight between transmitter pulse and an echo within the monitor gate
- measures the wall thickness between echoes of two monitors, either between echo peaks, edges or zero crossings
- provides 0.01 mm indication accuracy in echo-echo-mode
- allows evaluation also on curved surfaces (e.g. pipes)
- provides a VGA output for external monitors
- is delivered with a colour rubber protective holster to avoid sliding and for additional protection
- offers a separate adjustable gain in the third monitor, e.g. for individual backwall echo attenuation
- has an adjustable square pulser with a pulse width automatically adapted to the frequency of the probe when it is loaded, but which can be changed manually as well
- features digital filters for optimal adaption to the probe
- is dust-proof and provides protection against spraying water according to IP64

The ECHOGRAPH 1095 available in 4 versions:

- 1095 Basic
- 1095 DAC/TCG/AWS
- 1095 AVG/DAC/TCG
- 1095 AVG/DAC/TCG/AWS/JIS

Additional options available upon request:

- Matrix memory
- TOFD
- B-scan

## Packages and scope of supply

	order nos.
ECHOGRAPH 1095 Basic	1095.020
ECHOGRAPH 1095 DAC/TCG/AWS	1095.030
ECHOGRAPH 1095 DGS/DAC/TCG	1095.040
ECHOGRAPH 1095 DGS/DAC/TCG/AWS/JIS	1095.050

included in delivery:  
instrument with red protective holster,  
Li-ion rechargeable battery, mains/charging  
device and transport case

### Accessories for the standard package

Carrying case incl. belt	6189.101
Replacement carrying strap	6189.103
USB cable	1657.704
eCom 95, PC software for Windows XP/7/8 Desktop	1995.007
Spare battery pack 7.4 V; 7.6 Ah	1808.551
Charger unit for external charging of a spare battery	1808.531

## Operating the ECHOGRAPH 1095

The powerful ultrasonic flaw detector features 3 monitors for amplitude and time-of-flight measurement and 3 associated status lamps on the front panel for monitoring of threshold levels. The very compact instrument (54 mm case depth) provides fast digital ultrasonic electronics with a high sampling rate and pulse repetition frequencies up to 5000 Hz.

A convenient user guidance supports less-trained UT inspectors, also during probe handling and instrument adjustment: Simply activate the wizard and follow the instructions on the screen. Even difficult evaluation procedures for defect sizing (DAC/TCG, JIS, AWS and DGS) are carried out almost automatically.

The essential functions can be directly accessed via the foil keypad.

The 6 freely programmable function keys (F1 to F6) provide two different function levels. Switching between them is accomplished with the "SHIFT/MONITOR" button.

1st level:  
6 freely programmable function keys, here, for instance, direct access to: rectification, transmitter damping, device configuration, time of flight, zoom

2nd level:  
Adjustment of the three monitors (position, width, threshold)



Separate visual indications for evaluation of the monitor thresholds (M1, M2, M3)

The high-resolution display is easy to read with a clearly arranged indication of parameters.

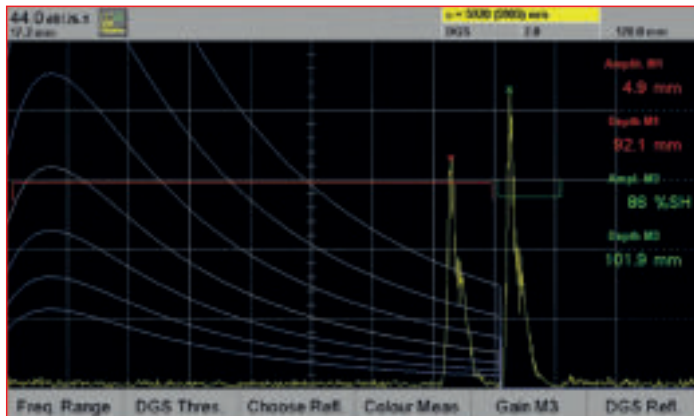

### Echo evaluation DGS method (option):

- Not restricted to special probes (DGS curve is calculated within the instrument)
- Visualisation of the reference DGS curve
- Defect size (FBH = flat bottom hole) is directly shown
- DGS with KARL DEUTSCH TR probes
- Indication of up to 6 additional threshold curves

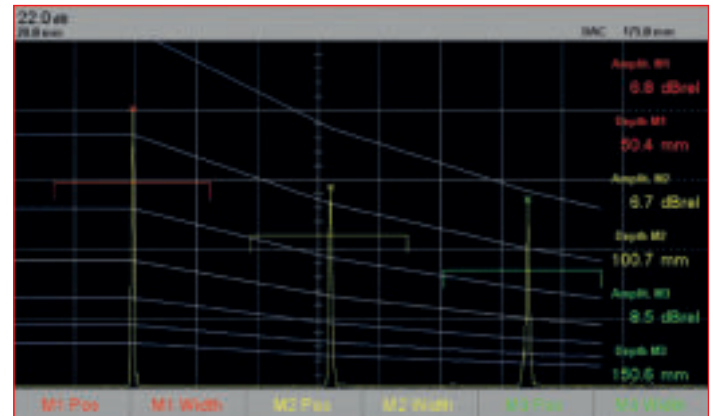

### Echo evaluation DAC method (option):

#### Reference line method (EN 1330-4)

- Optical and acoustical alarm when exceeding or dropping below the curve
- Indication of up to 6 threshold curves
- DAC support points can be manually added, shifted and deleted (up to 16 points)
- Calculation of time corrected gain (TCG) from the DAC curve



# Extensive Functions Application Examples

## Time Corrected Gain (TCG)

Clearly visible icon indicates the currently active evaluation method.

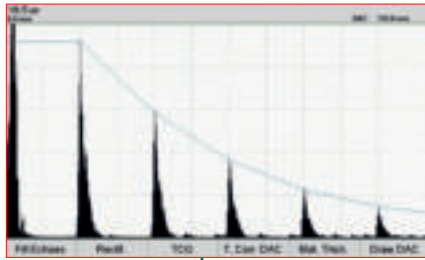

Recording of the DAC curve

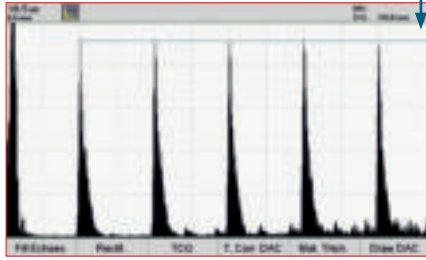

For TCG evaluation the gain is adjusted depth-dependent according to the previously recorded DAC curve.

## Backwall echo attenuation via separate gain in monitor 3

Clearly visible icon indicates the currently active evaluation method.



EVALUATION PARAMETERS	
STORAGE	Monitor 1 On (O)
PROBE	Monitor 2 On (O)
CALIBRATION	Measurement Selection On (O)
	Time of Flight On (O)
	Peak Edge On (O)
	G-Crossing On (O)
	B-Crossing On (O)
	Transmission Mode Off (O)
	Zoom Off (O)
	WALL THICKNESS
	Averaging (M1-M2) On (O)

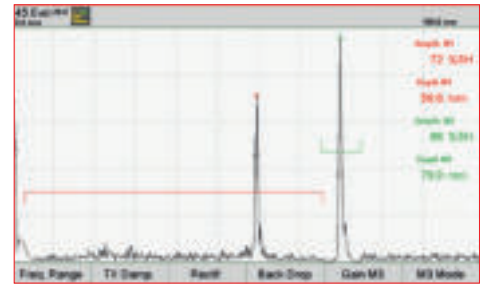

Gain of 28 dB inside monitor 3 and 45 dB outside

EVALUATION PARAMETERS	
STORAGE	Monitor 1 On (O)
PROBE	Monitor 2 On (O)
CALIBRATION	Measurement Selection On (O)
	Time of Flight On (O)
	Peak Edge On (O)
	G-Crossing On (O)
	B-Crossing On (O)
	Transmission Mode Off (O)
	Zoom Off (O)
	WALL THICKNESS
	Averaging (M1-M2) On (O)



## Wall thickness measurement

Precise wall thickness measurement between zero crossings with averaging and min/max storage (e.g. for corrosion mapping)

Current wall thickness value:  
|M1 - M2|  
Lowest wall thickness value:  
|M1 - M2| min  
Highest wall thickness value:  
|M1 - M2| max

## Adaption to curved surfaces

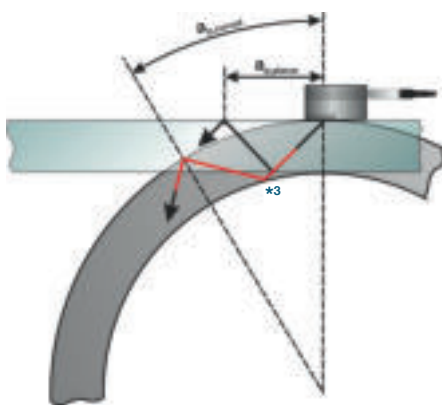

Calculation of defect depth and reduced projection distance considering the parameters of test object and probe.

Auto Adjustment	
Probe Name	WK 45 PB 4 (1)
Lead Probe	On (O)
Measurement Selection	On (O)
Sound Velocity	3255 (m/s)
Mode	Tube
Material Thickness	15.0 (mm)
Tube Diameter	250.0 (mm)
Next	Next

Monitor 1	
Evaluation Mode M1	SSH (O)
M1 Statistical Clearing	0
M1 Sound	Off (O)
M1 Signal Mode	Normal
Skip Marking M1	On (O)
M2 follows M1	Off (O)

Skip Marking M1	
Scan M1	0.3 Skip1
Deep M1	1.3 Skip1

\*1 automatic monitor positioning  
\*2 here: from 0.3 to 1.3 times the skip distance  
\*3 sound path marked in red



Clearly visible icon indicates the currently active evaluation method.

Depth M1	127.6 (dB)
Depth M2	0.0 (mm)
Fx - M1	18.5 (mm)

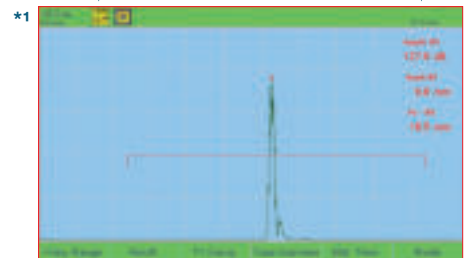

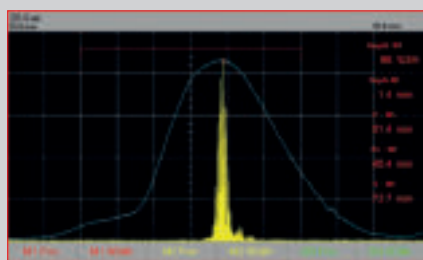

### Envelope Curve:

For evaluation of the echo dynamics the envelope curve can be recorded.

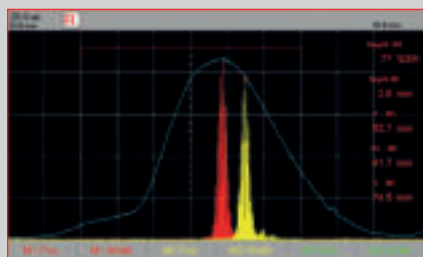

**Reference Curve:** Stored data can be used as reference curve. Thus, in case of repeated testing, the current result can be directly compared with the previous measurement.

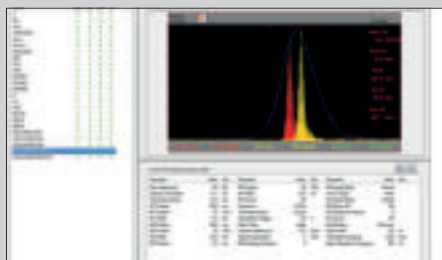

### Data Storage:

All data records are stored on a removable 8 GB SD flash card. Screenshots are saved as BMP files and measurement values as CSV files. Test reports can be easily created in a comfortable way with our eCom 95 software.

### ... overview of more features of the ECHOGRAPH 1095

- Rugged metal housing with rubber protective holster for rough environmental conditions
- Continuously adjustable stand with anti-slide coating
- Selectable screen colours for A-scan
- Antireflective protective glass
- USB interface
- Three optical indicators and an acoustical alarm output
- Energy saving mode in battery operation
- Built-in Li-ion-rechargeable battery ( built-in charging processor); charging of the battery also during test if connected to the mains power supply
- Easily exchangeable battery
- Use of SD flash cards up to 32 GB
- Update resp. upgrade via SD flash card and/or via unlock code
- Specifications acc. to EN 12668-1

### Screen

- Screen type**
- colour TFT LC display, transmissive
  - LED background illumination (with automatic adaption to the ambient light)

**Screen size** 152.4 mm x 91.44 mm

**Resolution** 800 x 480 pixel, 256 colours

**A-scan size** 152 mm x 76.2 mm

**Scaling** generated electronically

- Scale division**
- coarse: 10-fold horizontal, 5-fold vertical
  - fine: 25-fold horizontal

### A-Scan Representation and Digitizing

**Image refresh frequency** 60 Hz

- A-scan representation**
- normal display
  - filled echoes
  - frozen
  - echo dynamics curve (envelope curve)
  - zoom across monitor 1 and monitor 2
  - TOFD (on request)
  - B-scan (on request)
  - Reference curve

**RF representation** with zero crossing measurement

**Rectification** full wave, positive, negative

**Suppression** adjustable: 0 – 99 % screen height in 1 % steps (linear)

**Zoom** monitor range (monitors 1 and 2)

### Measuring Ranges

**Time-base range** 0.5 – 17760 mm steel

**Sound velocity** 200 – 15000 m/s in 1 m/s steps

**Pulse shift** 0 – 3000 mm in 0.1 mm steps

**Linearity of time base** ± 0.5 % of screen width

**Pulse repetition frequency** 10 – 5000 Hz, for square wave pulser up to 1000 Hz (automatic optimization [Auto High, Auto Low] or manual adjustment)

**Trigger** internal, external, 1st echo

### Transmitter

**Transmitter type** square wave pulser

**Transmission voltage** 60 – 320 V

**Pulse width** 30 – 5000 ns in 10 ns steps

**Transmitter damping** 50, 75, 220, 1000 [ $\Omega$ ]

### Receiver

**Frequency ranges** LP 0.2 – 2 MHz, 2 MHz, 4 MHz, 5 MHz  
Broadband 1.3 – 14 MHz, 10 MHz  
HP 4.9 – 22 MHz

**Adjustable gain** 110 dB in 0.1/1/2/6/12 dB steps

# Technical Data (continued)

## Echo Evaluation, Flaw Size Determination

<b>Display of echo height</b>	<ul style="list-style-type: none"> <li>• % screen height (%SH)</li> <li>• dBrel (DGS, DAC, TCG, JIS, AWS versions)</li> <li>• dBabs</li> <li>• indication rating acc. to AWS D1.1/1.1M</li> <li>• region of echo height acc. to JIS Z3060-2002</li> <li>• mmFBH (DGS option)</li> </ul>
-------------------------------	---

<b>Display of time of flight</b>	<ul style="list-style-type: none"> <li>• sound path</li> <li>• depth, projection distance and reduced projection distance</li> <li>• resolution 0.1 mm</li> </ul>
----------------------------------	---

<b>Display of wall thickness / sound velocity</b>	<ul style="list-style-type: none"> <li>• wall thickness measurement: 0.01 mm resolution (optional display of sound velocity to a given wall thickness)</li> <li>• min/max wall thickness</li> </ul>
---	---

## Options

<b>AWS</b>	AWS D1.1
<b>DAC/TCG</b>	max. 16 points, TCG 40 dB dynamic range
<b>DGS</b>	backwall, flat bottom hole or side drilled hole as reference
<b>JIS</b>	JIS Z3060
<b>TOFD/B-Scan</b>	on request
<b>Matrix memory</b>	on request

## Monitor

<b>Number of monitors</b>	3
<b>Response time</b>	with pulse repetition frequency (max. 5000 Hz)
<b>Operation modes</b>	normal, inverse, off
<b>Setting range</b>	<ul style="list-style-type: none"> <li>• monitor start: 0 – 20000 mm in 0.1 mm steps</li> <li>• monitor width: 0 – 3000 mm in 0.1 mm steps</li> </ul>

<b>Positioning</b>	<ul style="list-style-type: none"> <li>• independent manual adjustment</li> <li>• coupling of monitor 1 and monitor 2</li> <li>• automatic positioning depending on the skip distance for angle beam probes</li> </ul>
--------------------	--

<b>Visual indication</b>	3 LED's on front panel
--------------------------	------------------------

<b>Acoustical indication</b>	alarm sound
------------------------------	-------------

## Storage

<b>SD flash card</b>	8 GB standard card (up to 32 GB usable)
<b>Data format</b>	CSV
<b>Image format</b>	BMP

## Inputs and Outputs

<b>Probe connector</b>	2 x LEMO 1
<b>USB interface</b>	LEMO-B, 4 pin (adapter cable with USB type A)
<b>VGA output</b>	standard VGA socket (15 pin D-Sub)
<b>Trigger input/output</b>	LEMO-1B, 10 pin: TTL level (5V), low active

## Further Features

<b>Measuring units</b>	switchable mm, inch
<b>Date and time</b>	built-in real-time clock
<b>Languages</b>	English, German, further languages on request
<b>Permissible temperatures: Operation (with batteries/ storage temperature)</b>	-10 °C to +50 °C / -20 °C to +60 °C

## Power Supply

<b>Mains operation</b>	via mains power supply (article no. 1808.503) <ul style="list-style-type: none"> <li>• 100 - 240 VAC, 50 - 60 Hz</li> <li>• output: 12 VDC, 4 A</li> <li>• permissible operating temperature: 0 °C to +50 °C</li> </ul>
<b>Battery operation</b>	approx. 9.5 hrs (at factory settings) with built-in Li-ion rechargeable battery
<b>Power saving mode</b>	on / off
<b>Automatic switch-off</b>	in case of low voltage of mains or battery

## Dimensions and Weight

<b>Dimensions (H x W x D)</b>	<ul style="list-style-type: none"> <li>• 138 mm x 249 mm x 52 mm without protective holster</li> <li>• 149 mm x 262 mm x 54 mm with protective holster</li> </ul>
-------------------------------	---

<b>Weight</b>	• 2.0 kg (with Li-ion battery and protective holster)
---------------	---

**KARL DEUTSCH** Prüf- und Messgerätebau GmbH + Co KG  
 Otto-Hausmann-Ring 101 · 42115 Wuppertal · Germany  
 Phone (+49-202) 7192-0 · Fax (+49-202) 71 49 32  
 info@karldeutsch.de · www.karldeutsch.de

DIN EN ISO  
9001  
certified

**KARL DEUTSCH**