

Series 1600

Computer-Controlled
Universal Testing Machines



With TestVue® for Windows™

Introduction

ATS Series 1600 Computer-Controlled Universal Testing Machines with TestVue® software provide maximum versatility at an affordable price.

Outstanding Features:

- Control on displacement, load, strain, or strain rate
- Automatic crosshead return
- Manual control at frame
- Automatic load cell verification
- Testing may be initiated from computer or test frame
- Automatic overrange and overload protection
- Multiple segment testing
- Optical encoder for precise crosshead displacement
- On-screen help
- 10 KHz data acquisition rate
- User-definable averaging and data reduction algorithm
- Password protection
- Serial number identification for transducers
- Traceable closed-loop calibration
- Multiple user-definable report formats
- Network-compatible file handling
- User-definable auto scaling graphs
- Automated analysis/report outlines
- Testing integrated with output from temperature controllers
- Supports external measuring devices
- User-configurable virtual channels

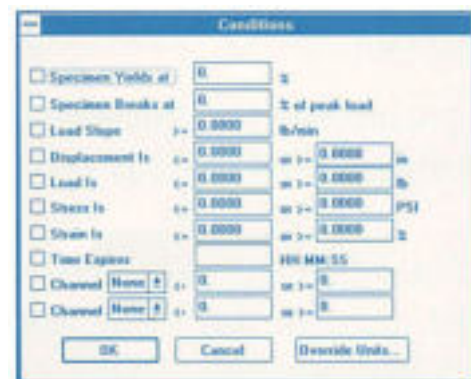
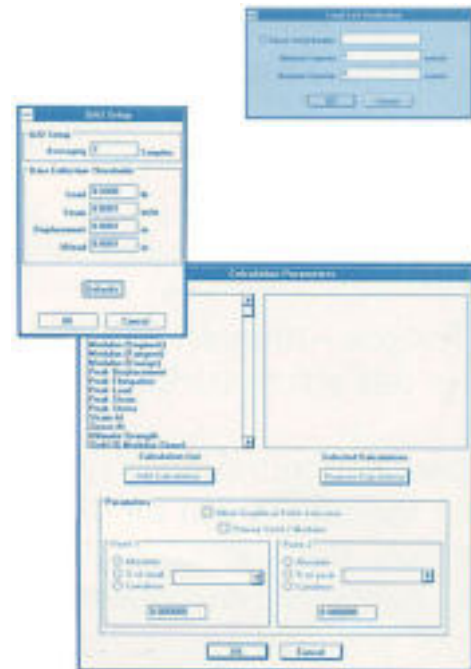

Enhanced control in the various test modes is achieved through the use of precision twin ball screws, driven by a highly efficient servo motor and state-of-the-art motion control technology.

A single test can be assembled from segments or blocks that can use different control modes. This allows unlimited flexibility in building complex tests.

Software

TestVue® software is capable of supervising all aspects of load frame motion and testing. These functions include:

- Manual control of load frame motion
- Test parameter setup and control
- Automatic control of UTM
- Data acquisition and storage
- User-interactive graphics
- Data analysis and reporting



- Versatile enough for even the most demanding test procedures yet simple enough for all users to understand and operate.
- Testing procedures can be automated to the point that even complex tests may be executed with only a few keystrokes.
- The user is prompted through each menu until testing is ready to begin.
- Manual control station allows repetitive testing from the frame and permits simple testing without the use of the computer.

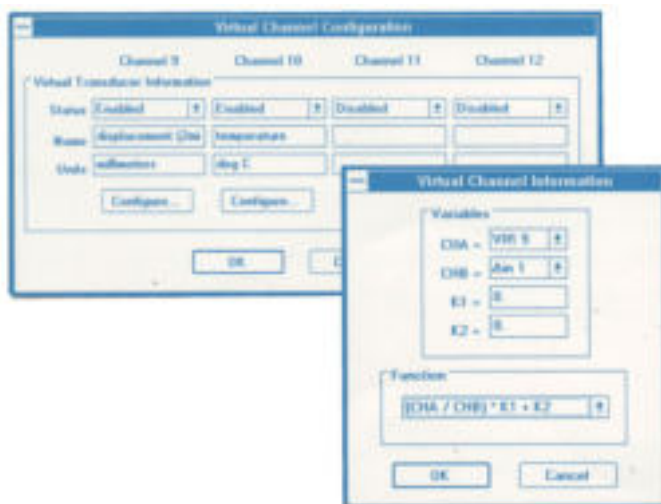

Virtual Channels

In addition to the physical analog and digital input channels, a maximum of four virtual input channels is available. The user may define the channels as desired, i.e., A-B, A+B/2, etc. Channel configuration is then stored as part of the test specification.

Data Analysis

- A built-in data analysis menu is available to allow the user to select analysis functions that the system automatically performs at test completion.
- In addition, analysis of batch information is provided in a post-test format. Fully-interactive graphics capability allows maximum flexibility.
- The user has complete control of specimen manipulation for analysis purposes.

Report Generation

Report configuration can be included in the test specification, in which case a report will be generated automatically at the end of the test. Alternatively, the operator can recall previously stored test data, perform analysis, and generate reports at any time, regardless of whether or not such options were included as part of the test specification. The following three report options are available:

- **Standard pre-configured report structure:** All pertinent data and analysis results selected by the user are presented in tabular format.
- **Microsoft® Excel™ macros:** To provide custom data analysis and report generation, user-specified Excel™ macros can be automatically utilized to generate reports.
- **Templates:** When data needs to be presented in a specialized format, TestVue® will merge data with templates which can be created through Microsoft® Word™.

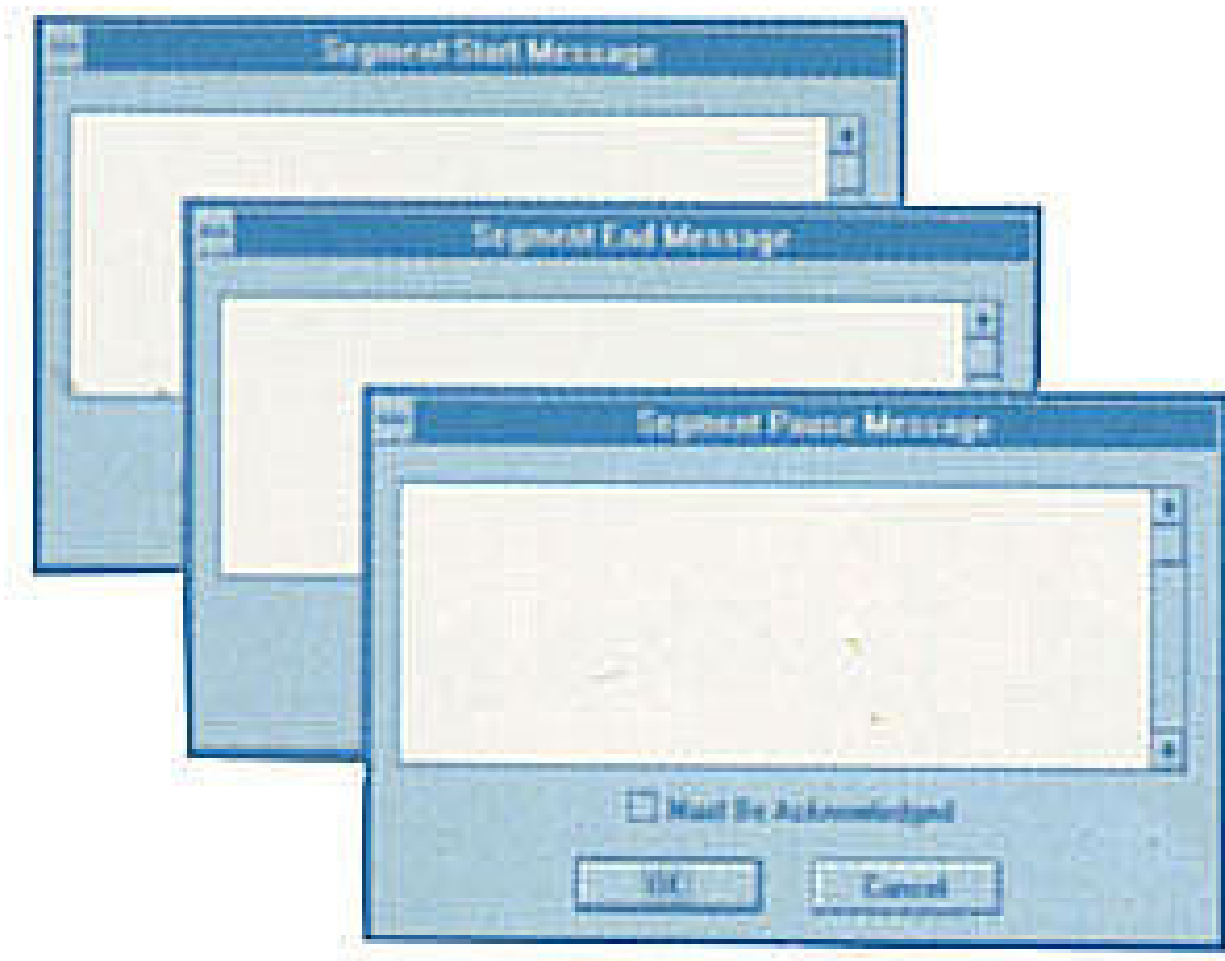

The Microsoft® Windows™ menu structure allows the operator to perform all selection and configuration tasks via mouse or keyboard input. All entries are saved as part of the test specifications.

A convenient frame-mounted manual control station allows limited operation of UTM functions, including the following:

- Push-button actuated crosshead zero reset and return to zero position.
- Ability to start, stop, pause, and resume the currently selected test procedure.
- Manual control of moving crosshead, allowing for easy test setup and positioning.

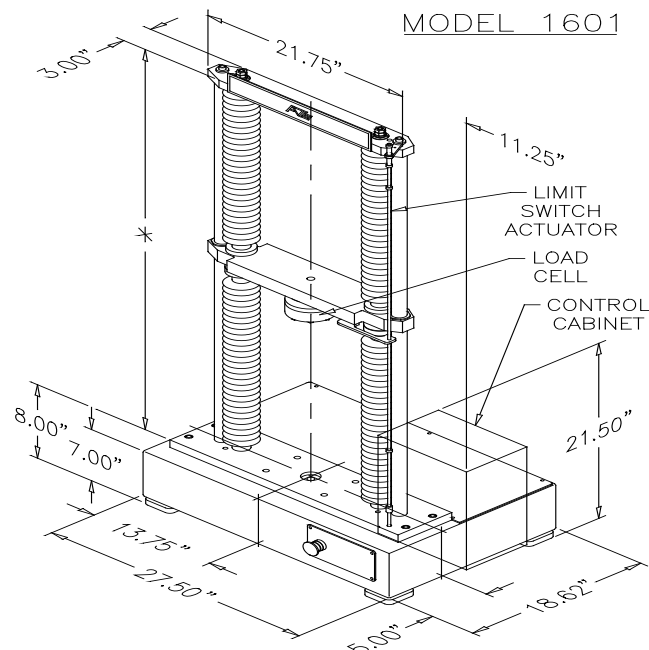

* MACHINE HEIGHT VARIES BASED UPON REQUIRED CROSSHEAD TRAVEL / VERTICAL CLEARANCE.

SEE SPECIFICATIONS SHEET FOR USABLE HORIZONTAL CLEARANCE.

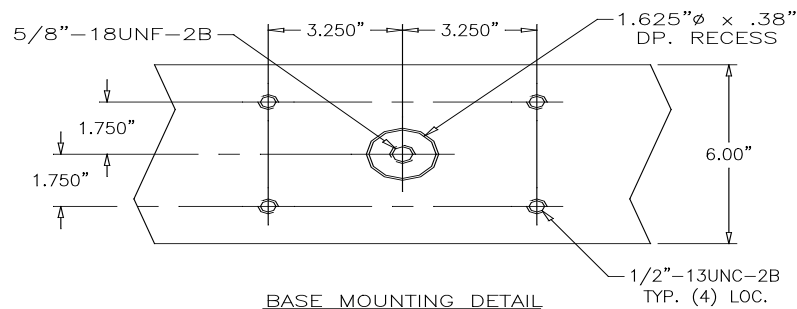

Features

ATS Series 1600 Universal Testing Machines are the perfect choice where complex or repetitive testing with the convenience and repeatability of a computer-controlled system is desired in capacities up to 67,440 lbs.

All models are designed to be as compact as possible, consuming a minimal amount of precious laboratory space, while providing a maximum of available testing area, easily accommodating various sizes of chambers, fixtures, and samples.

Accuracy of test results is ensured by a durable twin-screw drive system with hard-chrome plated guide rods and a precise motion control system.

Additionally, a wide variety of accessories is available to provide extended capability and flexibility, including furnaces, heating and cooling chambers, recorders, fixtures, grips, and more.

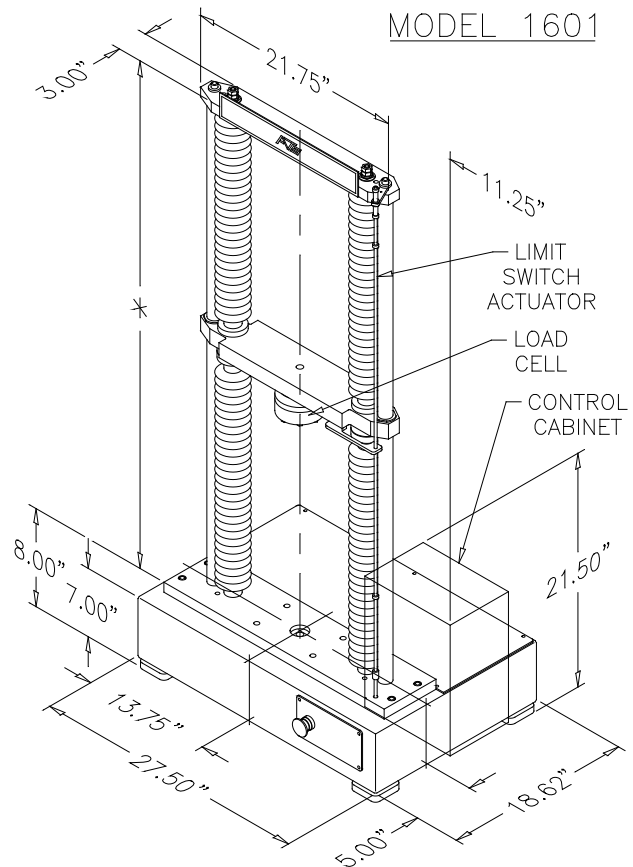

* MACHINE HEIGHT VARIES BASED UPON REQUIRED CROSSHEAD TRAVEL / VERTICAL CLEARANCE.

SEE SPECIFICATIONS SHEET FOR USABLE HORIZONTAL CLEARANCE.

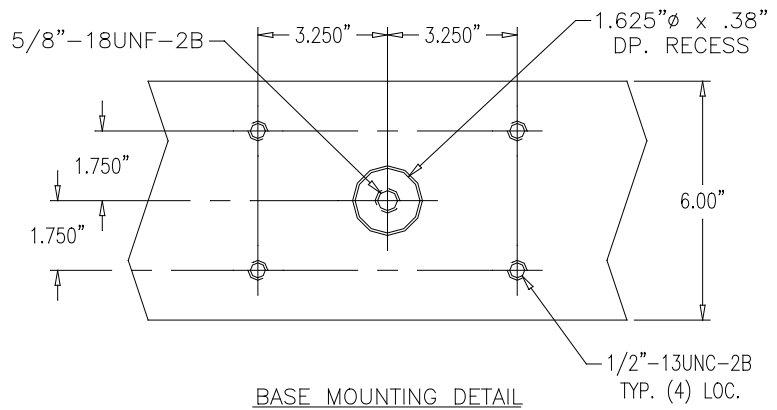

Load Frames

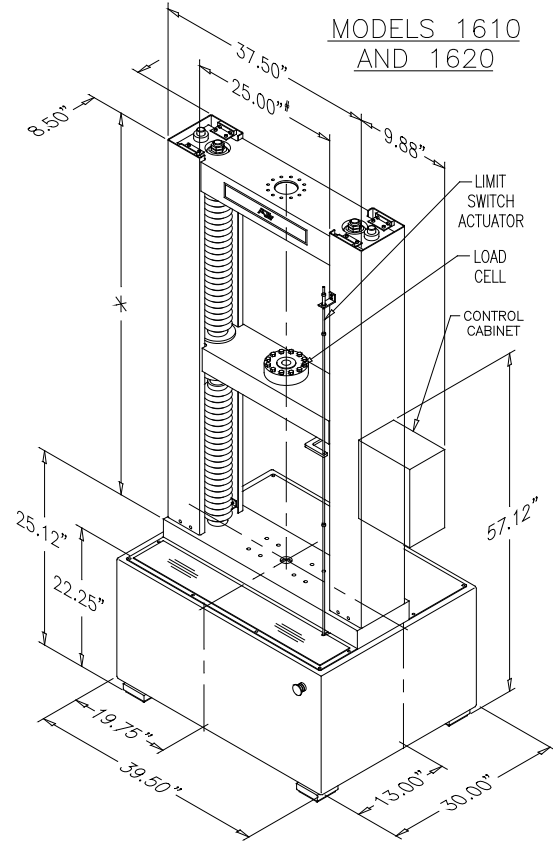
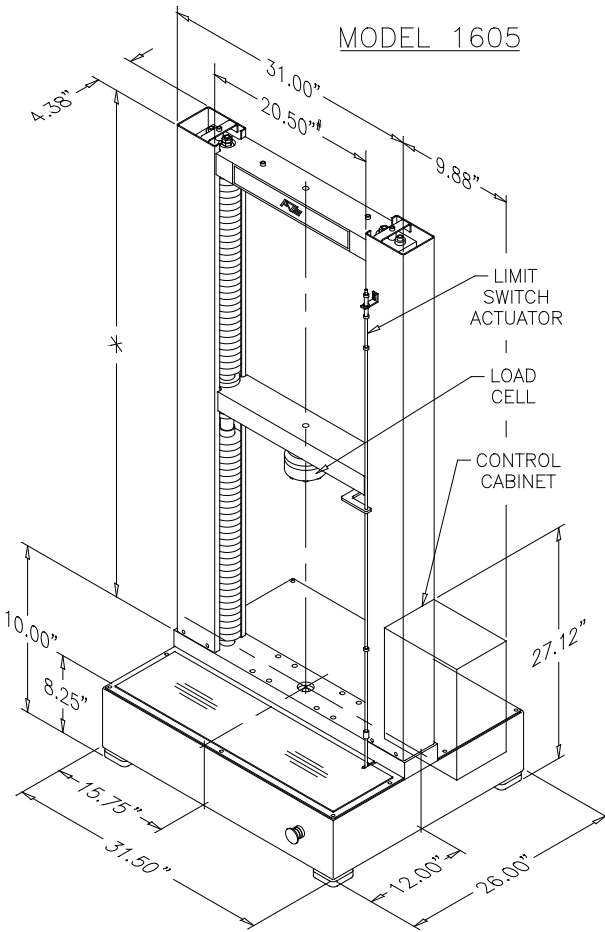

DISTANCE SHOWN IS BETWEEN UTM COLUMN SHROUDS. SEE SPECIFICATIONS SHEET FOR USABLE HORIZONTAL CLEARANCE.

DISTANCE SHOWN IS BETWEEN UTM COLUMN SHROUDS. SEE SPECIFICATIONS SHEET FOR USABLE HORIZONTAL CLEARANCE.

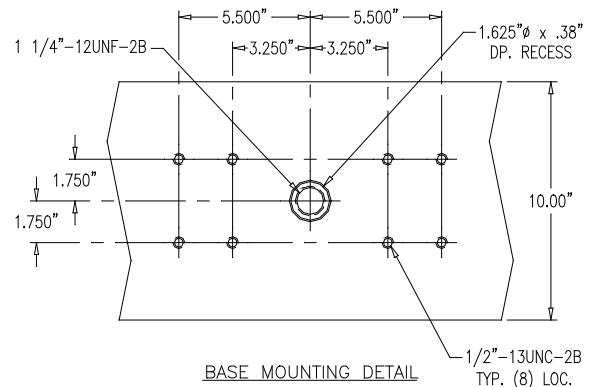
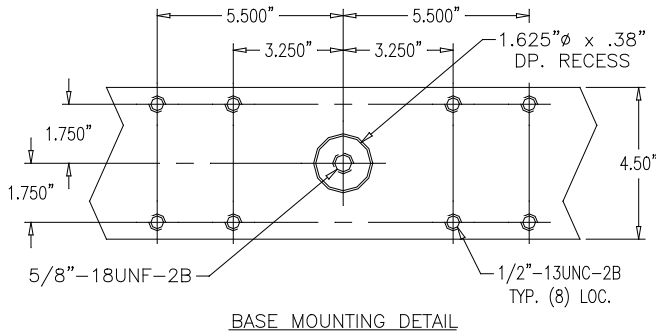

Load Frames

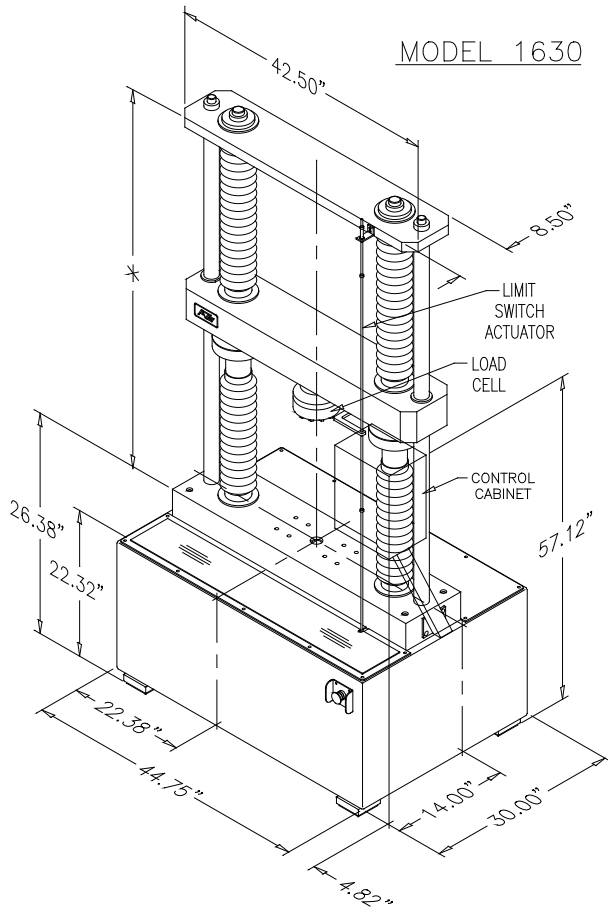

* MACHINE HEIGHT VARIES BASED UPON REQUIRED CROSSHEAD TRAVEL / VERTICAL CLEARANCE.

SEE SPECIFICATIONS SHEET FOR USABLE HORIZONTAL CLEARANCE.

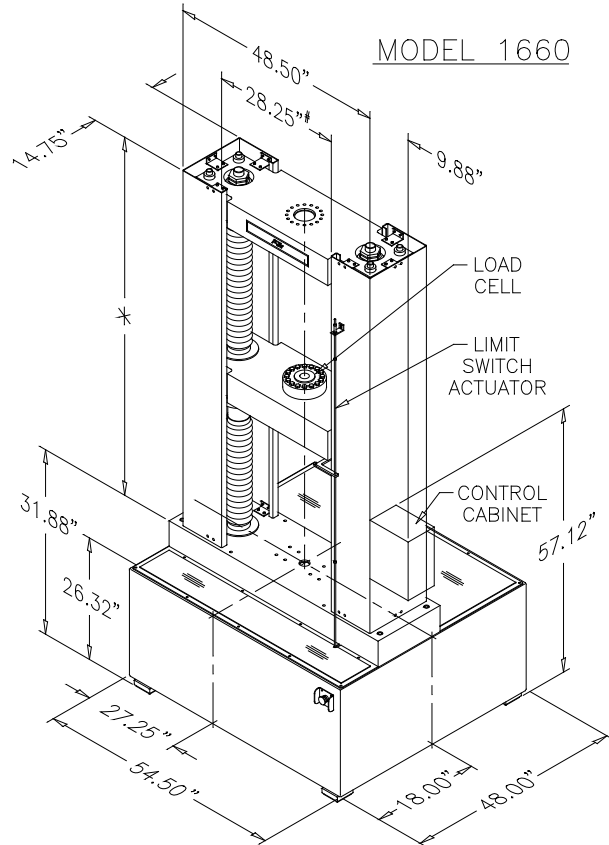

* MACHINE HEIGHT VARIES BASED UPON REQUIRED CROSSHEAD TRAVEL / VERTICAL CLEARANCE.

DISTANCE SHOWN IS BETWEEN UTM COLUMN SHROUDS. SEE SPECIFICATIONS SHEET FOR USABLE HORIZONTAL CLEARANCE.

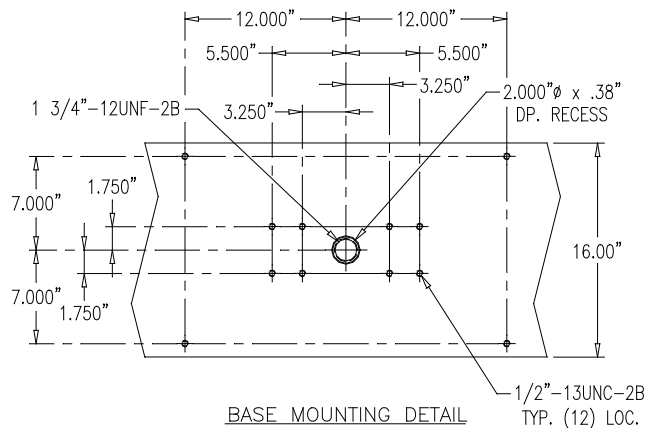
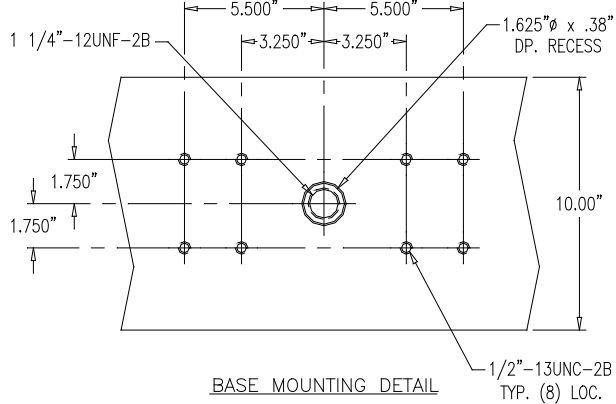

Specifications

LOAD FRAME	1601	1605	1610	1620	1630	1660
Capacity	1,000 lbf. (4.4kN)	5,000 lbf. (22.2kN)	10,000 lbf. (44.4kN)	22,480 lbf. (100kN)	33,720 lbf. (150kN)	67,440 lbf. (300kN)
Horizontal Clearance	12 in. (304mm)	18 in. (456mm)	22 in. (558mm)	22 in. (558mm)	23.5 in. (596mm)	28 in. (712mm)
Type	Bench top	Bench top	Floor model	Floor model	Floor model	Floor model
Testing Area	Tension and compression below moving crosshead					
Crosshead Guidance	Twin-screw drive with independent chrome-plated guide rods					
Vertical Clearance	42 in. (1066mm) STANDARD, excluding grips or fixtures*					
Crosshead Travel	42 in. (1066mm) STANDARD*					
Limit Switches	Manually adjustable					
Safety Features	A large red "panic button" shuts down all mechanical functions in the event of an emergency					

CROSSHEAD CONTROL & DISPLACEMENT MEASURING

Speed Range	0.002-20.00 in./min (0.1-500.0 mm/min)
Speed Accuracy	±0.05% of indicated speed
Position Accuracy	±0.0005 in. (0.01mm)
Automatic Control	Computerized operation using ATS TestVue® software
Manual Control	Frame-mounted controls allow limited operation of the UTM

LOAD MEASURING

Load Weighing Accuracy	±0.5% of indicated load ±0.1% of full scale
Strain Accuracy	±0.05% of full scale
Overload Protection	STANDARD
Analog Inputs	2 STANDARD 2 OPTIONAL
Analog Outputs	2 OPTIONAL

REQUIREMENTS

Power Requirements	120 or 240 VAC, 1 Phase, 50/60 Hz
--------------------	-----------------------------------

SOFTWARE

System Requirements	OS: Microsoft® Windows™ 9x (95, 98, Me) or NT (4.0, 2000, XP) Processor: Intel® Celeron™ (or equivalent) 500MHz or higher Memory: 64MB RAM or higher Hard Disk: 5GB or larger CD-ROM: Required Display: 800x600x256 or better I/O: One available RS-232 communications port is required
---------------------	---

* Extended crosshead travel and vertical clearance are available.

Specifications subject to change without notice

Custom Equipment

Applied Test Systems, Inc. has an excellent reputation in the materials testing industry as a leading supplier of custom equipment. We welcome all inquiries into any system or setup you may have in mind. Below are just a few examples of how we can put our decades of experience to work for you.



Series 1120C UTM integrated with a 60" span bend test fixture. Used for static testing of timbers per ASTM designation D198-84.



Series 1105C UTM with extended crosshead travel and vertical clearance. Equipped with special platens for testing of large-diameter plastic pipe.



ATS APPLIED TEST SYSTEMS, INC.

154 East Brook Lane
Butler, PA 16002

Phone: (724) 283-1212
Toll-Free: (800) 441-0215
Fax: (724) 283-6570
eMail: sales@atspa.com
<http://www.atspa.com>

CE Certification Program Now Available

