

FEP ME 640 AMX

ADVANCED MULTIVIEW X-RAY



SECURITY TECHNOLOGY

FEP ME 640 AMX

FEP ME 640 AMX – Advanced Multiview X-ray – introduces multiview technology for hand baggage check. With a small footprint and excellent image quality it is the ideal checkpoint solution. Its compact design makes checkpoint redesign unnecessary. FEP ME 640 AMX displays two orthogonal views for a more accurate and detailed inspection independent of bag placement on the belt, dramatically reducing the need for re-scans. High quality images featuring the greatest penetration and resolution on the market show the object under examination with superior detail.

NEW INSPECTION

- Tunnel size: 60cm x 40cm
- State-of-the-art dual energy multiview detection technology
- High quality B&W and color images
- Reveals threat items, organic and inorganic materials inside carry-on bags
- New view for precise in-depth inspection
- New baggage photocell sensor prevents cut-off images
- Upgradable platform for detection of solid and liquid threats

NEW IMAGING

- Same software and user interface of other FEP ME family models
- Multiple independent images
- Highest penetration and resolution

- High detail definition
- Real-time 24 bit image processing
- Automatic color coding of materials with different Z atomic number (organic, inorganic, metallic)
- On-the-fly post-processing features

SIMPLY POWERFUL

- Based on the powerful operating system Linux for improved real-time data processing
- Intuitive user-friendly interface
- Multi-level access protected by password or smart-card
- New Archiving Image Management System for saving work sessions
- Easy data import and export
- High interoperability
- Client-server platform
- Windows compatible

NETWORKING

- Complete network capability
- Data sharing via network
- TIP reports and configurations accessible from supervisor station
- Central archive of all work sessions and images acquired on the network (networking AIMS)
- Management of network operating settings from remote supervisor workstation
- Further screening from remote operator workstation(s)
- Multilevel inspection system
- Fully compatible with all GILARDONI equipment

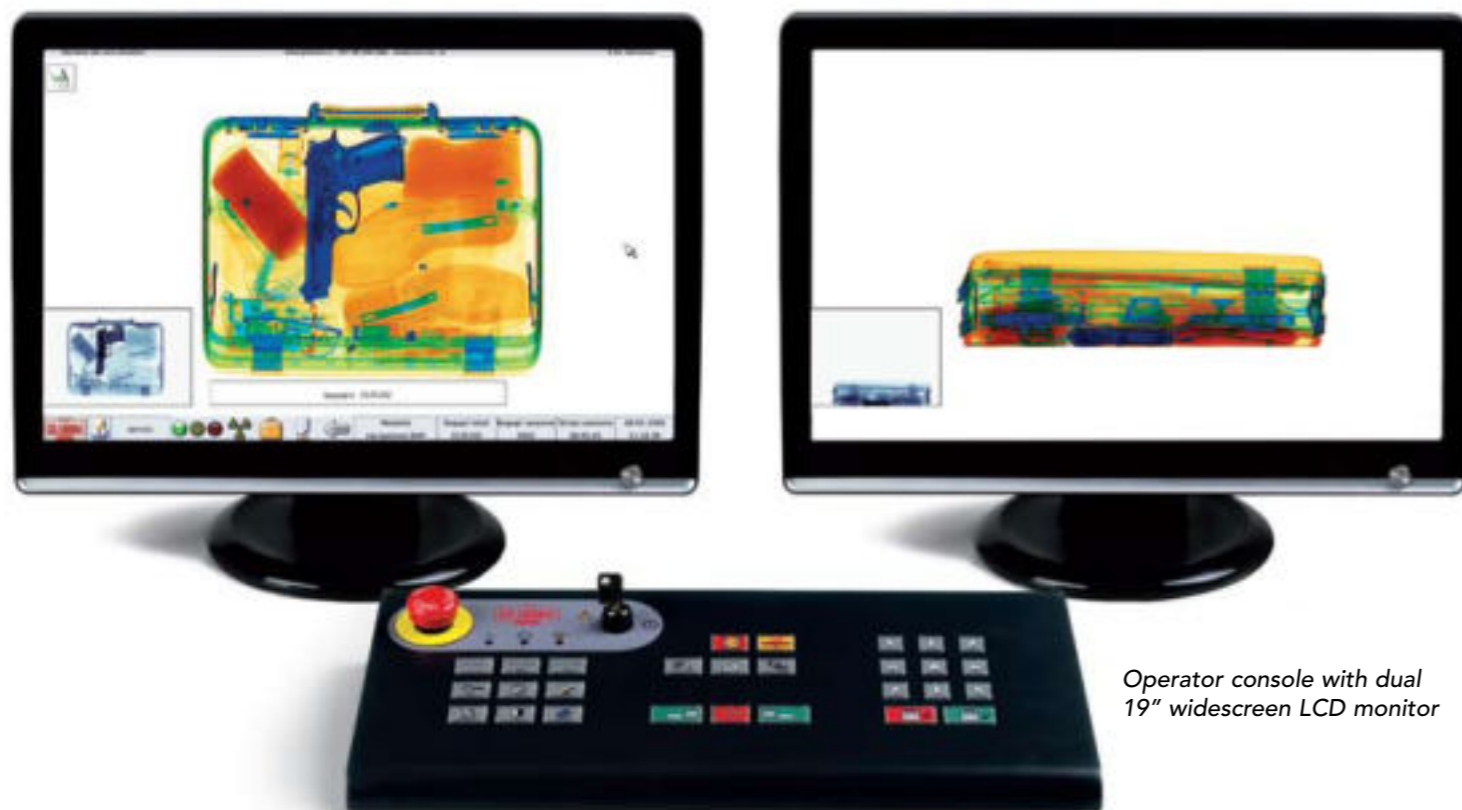

Operator console with dual 19" widescreen LCD monitor

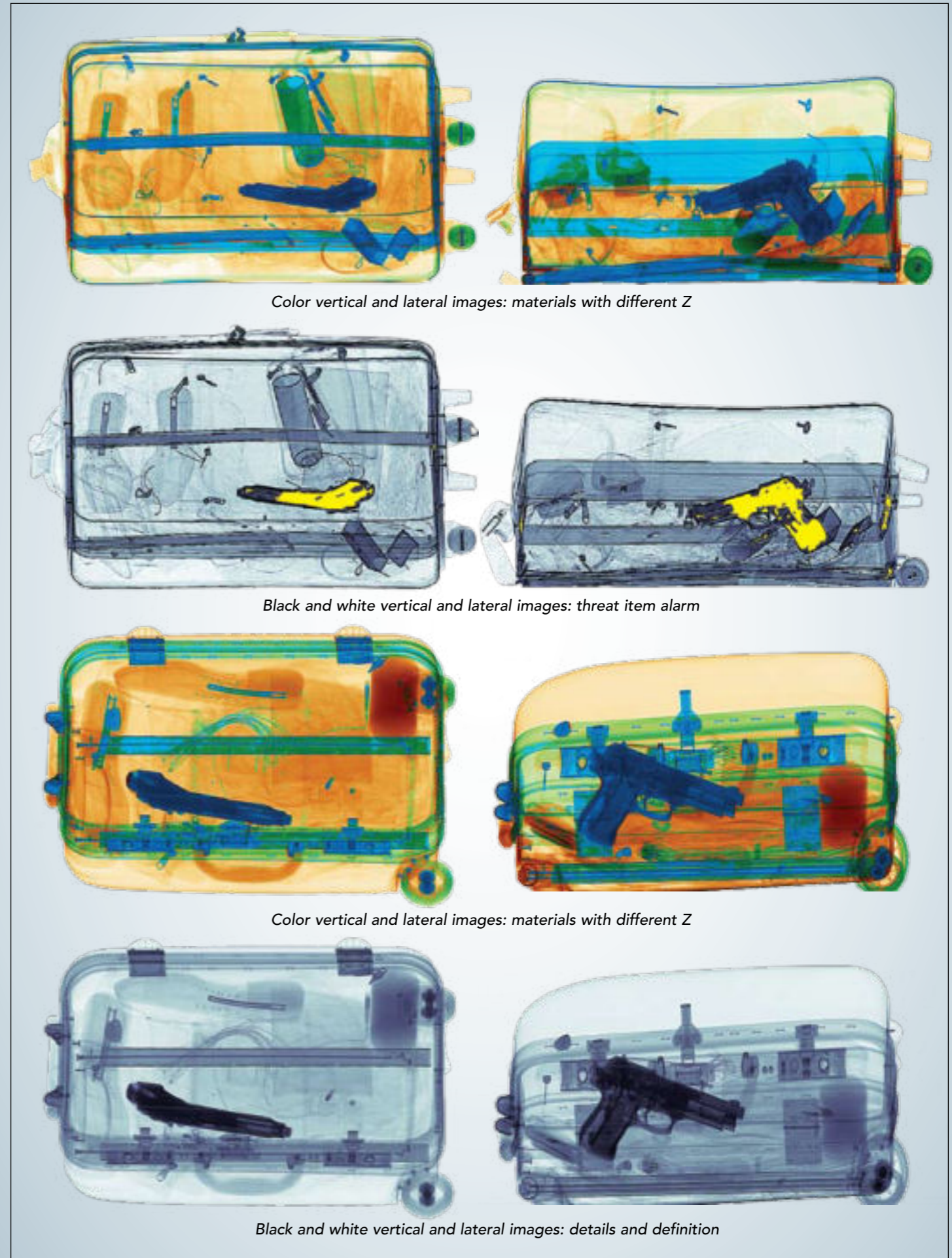

Color vertical and lateral images: materials with different Z

Black and white vertical and lateral images: threat item alarm

Color vertical and lateral images: materials with different Z

Black and white vertical and lateral images: details and definition

TECHNICAL SPECIFICATIONS

Inspection unit

- Dimensions: 2680mm (L) x 1180mm (W) x 1257mm (H)
- Weight: 900kg
- Tunnel size: 606mm (W) x 405mm (H)
- Conveyor belt height: 690mm (adjustable)
- Belt speed: 0.2m/s
- Maximum bag weight: 165kg
- 2 19" LCD widescreen monitors SVGA 1280x1024
- Power supply: Monophase 230VAC +/- 10%
- Frequency: 50/60Hz +/- 3Hz
- Power absorption: 2kVA
- Duty cycle: 100%

X-Ray generator

- Multiple high frequency monoblocs
- Tube voltage: 150kV
- Tube current tube: 0.5mA
- Beam Orientation: Diagonal upwards and lateral

Environmental compliance

- Operational temperatures: 0°C to 40°C
- Storage temperature: -20°C to +60°C
- Humidity: 95% without condensation
- Protection class: IP22
- Noise level: < 60dB

Detection characteristics

- Resolution: 38 AWG guaranteed, 41 AWG typical in each view
- Penetration: 27mm steel guaranteed, 30mm steel typical
- Multiview detection system in L-shaped rows of photodiodes

Health and Safety

- The system fully meets the applicable international regulations for X-Ray equipment
- Leakage dose at 10cm: < 1.0µSv/h (0.1mR/h)
- Film safety: guaranteed up to ISO 1600/33 DIN

Options

- ADS
- TIP
- NetServer & TIPNet
- Digital image archiving (AIMS)
- AIMS Networking
- Modular roller tables
- Monitor enclosure
- Remote workstation(s)
- UPS

REFERENCE REGULATION: EC, IEC, TSA, STAC, DFT, ENAC



Dimensions in mm

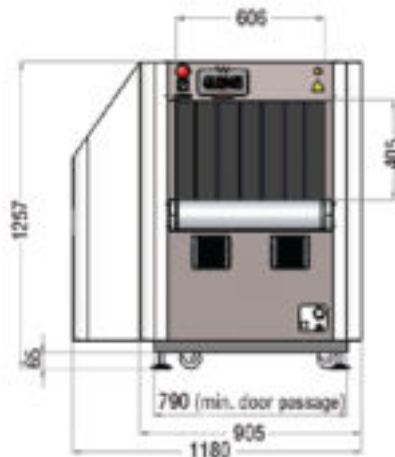

Reserving the right to improve and modify

RESEARCH LABORATORIES acknowledged "Highly Qualified" with decree D.M. 9-10-1985 – L.46/82 art.4

Head office and facilities:

Via **Arturo Gilardoni**, 1 - 23826 Mandello del Lario (LC) - Italy
tel. (+39) 0341-705.111 - fax (+39) 0341-735.046
e-mail: gx@gilardoni.it - www.gilardoni.it

Export department:

tel. (+39) 0341-705.311 - 0341-705.224 e-mail: secur.export@gilardoni.it

