



PARKER RESEARCH CORP.

NONDESTRUCTIVE TEST METHODS, SYSTEMS, INSTRUMENTS
BOX 1406, DUNEDIN, FLORIDA, U.S.A. 34697
PHONE: (727)796-4066 FAX: 1 (727)797-3941

The Parker Y-300 and Y-400 Probe Lights are molded inspection lights designed to fit the B-300 and DA-400 Contour Probes. The lights produce substantial close-in illumination for magnetic testing.

The Parker Probe Lights operate from the induction of the AC magnetic field produced by the Yokes. A small coil wound within the molded light housing produces 12 volts AC which operates the small cylindrical shaped bulb. There are no wiring connections necessary for installation. It should be noted that the lights operate in the AC mode only.

The Y-300 Probe Light is designed to fit the rear leg housing of the Parker B-300 Contour Probe while, the Y-400 is designed to fit the rear leg housing of the DA-400 Contour Probe. Both are molded from durable glass filled nylon which is extremely resistant to shock, wear and chemicals. The bulbs are an automotive dome light bulb which may be available from local sources. Replacements are also available from Parker at minimal cost.

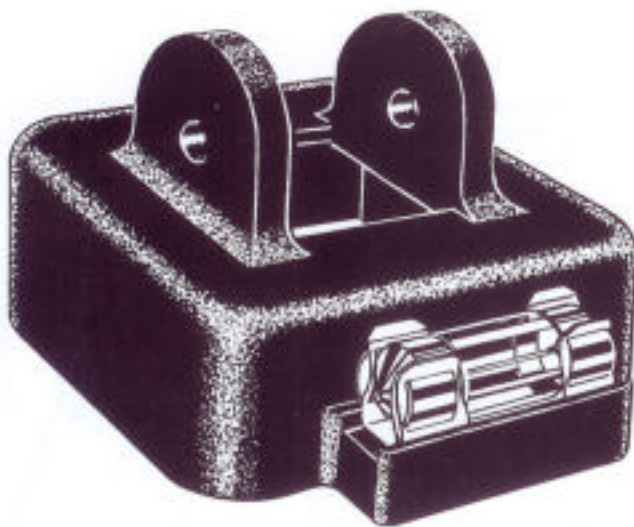

Y-300 PARKER PROBE LIGHT
Fits B-300 Contour Probe

Y-400 PARKER PROBE LIGHT
Fits DA-400 Contour Probe

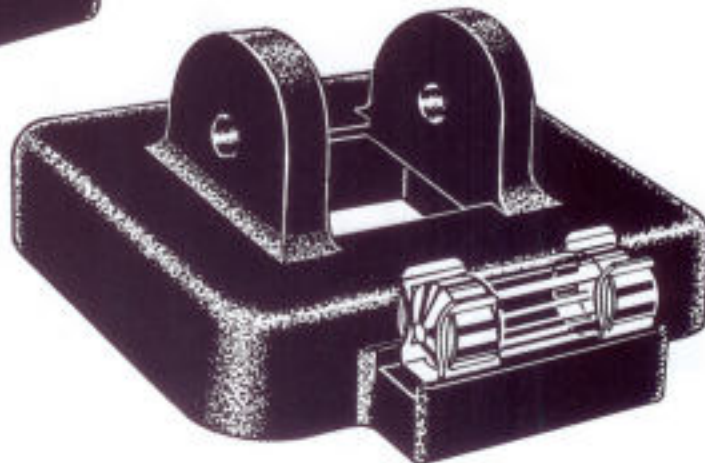

See reverse side for installation instructions.

Y-400 and Y-300 Parker Probe Light
(For the Parker DA-400 and B-300 Contour Probes)

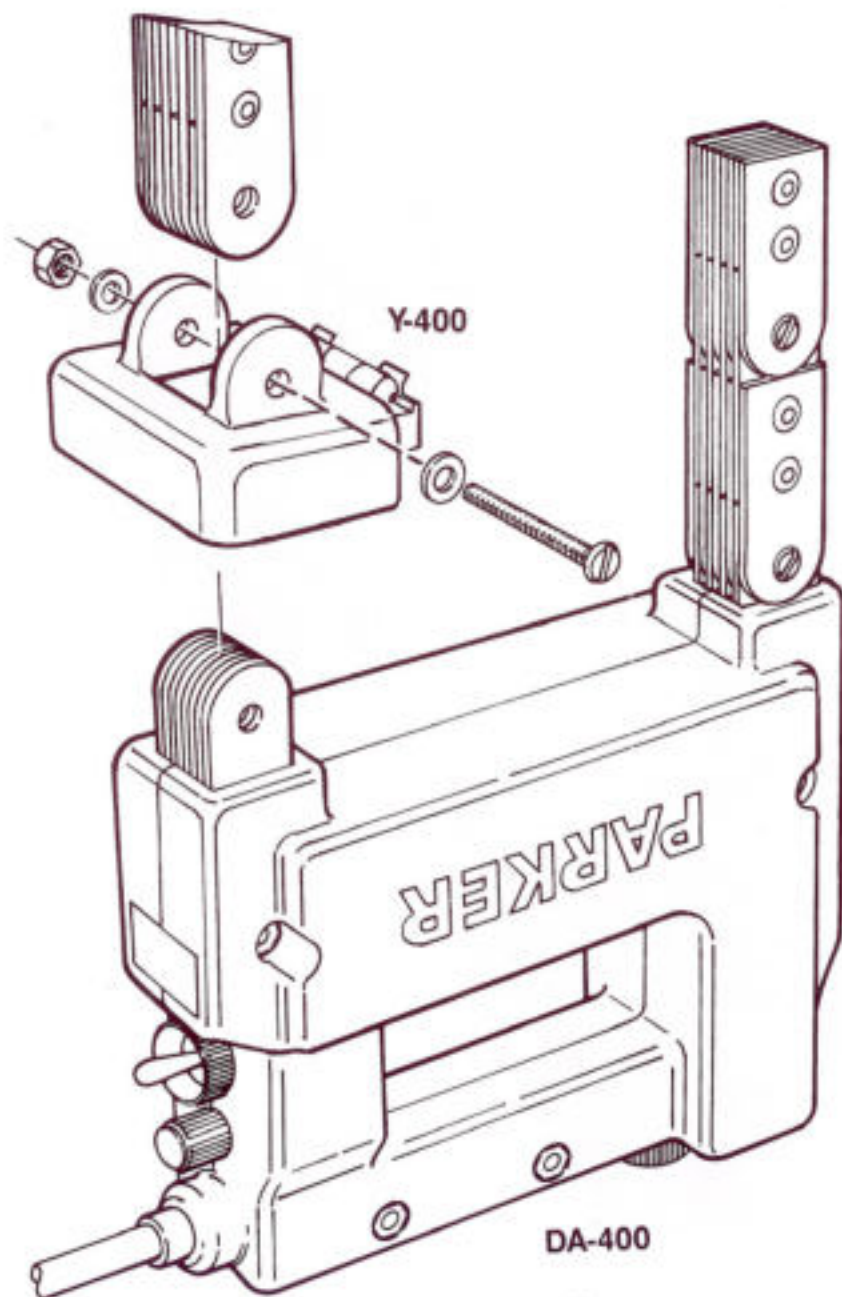

INSTALLATION INSTRUCTIONS:

1. Remove existing screw and nut from rear Probe leg (closest to power cord).
2. Remove Probe leg.
3. Install Probe Light over leg attachment with light facing forward.
4. Reinstall rear Probe leg.
5. Insert new 1-3/4" screw using the washers on either side.
6. Attach nut and tighten.

