

EDDY CURRENT TESTING FOR SAFE COMPONENTS



DIVISION CT

... the FOERSTER Group component testing division

Competence through innovative and worldwide presence

Division CT is based in Dortmund. It develops and produces eddy current devices for non-destructive testing of metal components. From Dortmund, the sales department supports customers in more than 50 countries through subsidiaries and branch offices.



▲ FOERSTER
Division CT in Dortmund

Efficient testing of automobile components with eddy current

The highly developed manufacturing technologies used in today's automobile engineering require reliable and fully automatic quality control by manufacturers and suppliers for controlling and monitoring the various processes.

The reasons for this are:

- The increased requirements for safety and efficiency
- The provisions of the product liability law
- The need for documentation
- The demonstration of a quality management system by certification

Qualified application and sales engineers work closely with the user to determine the best possible testing system configuration from a technical and economical point of view.



With its subsidiaries, branch offices and agencies around the world, FOERSTER is never far away from you.

www.foerstergroup.de

The FOERSTER Group web site introduces Division CT with industrial application examples. It also portrays the historic development and provides access to the technical documentation of the products.



◀ FOERSTER
Head office in Reutlingen

CONTENTS

Basics

Eddy current technology	4
Crack detection	5
Material and microstructure testing	6
Multi-frequency testing and Higher harmonic evaluation	7
Crack detection with test electronics and sensor systems	8 / 9
Material testing with test electronics and sensor systems	10 / 11
Assistants and Regression	12
Testing concepts	13

Certificates	31
---------------------	-----------



DIVISION TS
SEMI-FINISHED
PRODUCT TESTING



DIVISION CT
COMPONENT TESTING















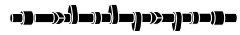



DIVISION DM
METAL DETECTION
& MAGNETICS



DIVISION M
MOBILE TESTING AND
MEASURING EQUIPMENT

Examples of application

Piston rods/piston pins		14
Bearings		15
Valves/valve tappets		16
Valve seat rings		17
Cylinder bores		18
Camshafts		19
Turned parts		20
Axle pivots		21
CV-Joints		22
Brake discs		23
Gearbox shafts		24
Wheel hubs		25
Ball pins		26
Gear racks		27
Rolls		28
Drive shafts		29
Valve seats		30

EDDY CURRENT TECHNOLOGY

The eddy current technology

The eddy current technology as per EN 12084 does not only detect material discontinuity and imperfections such as cracks, laminations, pores or cavities on the material surface. It also makes it possible to check materials for their properties to identify faults such as material mix-ups or differing heat treatment conditions. Some of the typical sorting criteria are alloy proportions, surface hardness, hardness depth, strength and microstructure characteristics. The eddy current technology is non-destructive and works without physical contact. Additional media, such as coupling liquids, are not required. Even parts with delicate surfaces can easily be tested.



▲ Example of a surface defect located during automatic testing.



▲ Typical microstructure formation.

Fundamental advantages of the Eddy current technology compared to other processes

- High testing speed
- High test throughput
- Easy to automate
- 100 % testing
- Objective result evaluation
- High reproducibility
- Documentation and recording of test results
- No contamination by coupling liquids

CRACK DETECTION

Detecting cracks in the material

For crack detection, the surface of the part to be tested is scanned without physical contact by one or more eddy current probes. For this purpose, the test item can be rotated by a mechanism adapted to suit the task and scanned by a stationary probe. Alternatively, a rotating probe can scan the stationary test item.

The system can incorporate either one test track along the circumference with one probe only, or several test tracks with probes arranged in parallel. Alternatively, the surface of the part to be tested can be scanned with a probe which tracks the contour of the part. The choice of probes depends on the geometry of the component, the cycle time and the defect specification.

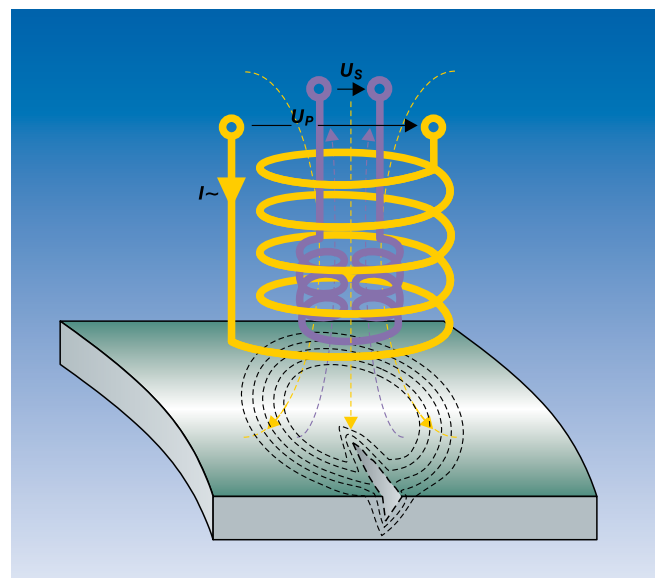

▲ The illustration shows how a crack, for example, affects the characteristics of the eddy current in a conductive metal material.

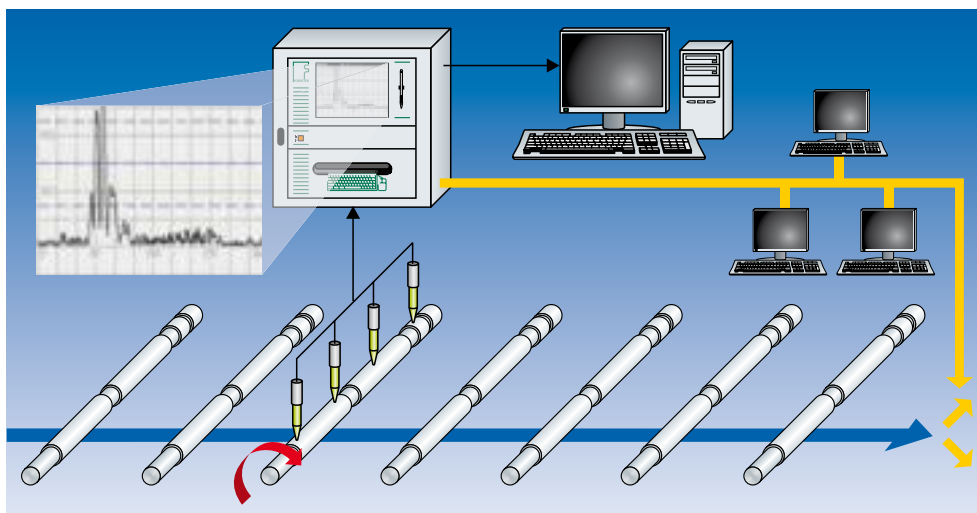

▲ Eddy current crack detection without physical contact can also be integrated into more complex manufacturing sequences. The illustration shows how the components are detected during 100 % testing in the automated testing process while the test results are documented online and the data is processed for documentation. In addition, the sorting of defective parts is carried out.

MATERIAL AND MICROSTRUCTURE TESTING

Checking materials for their properties

For testing of material properties, the specimens are passed through an encircling testing coil. For special applications, e.g. for local checks for surface hardness or hardness penetration, sensor systems adapted to suit the specimen are provided. The voltage detected by the individual sensors results from the magnetic and electric properties of the specimen. The exact voltage is graphically displayed as a measuring point. Due to the statistical evaluation of several measured values, a sorting limit is automatically created during calibration. During subsequent serial testing, all further measuring points are compared with the specified tolerance limits. The parts are sorted according to the respective test result.

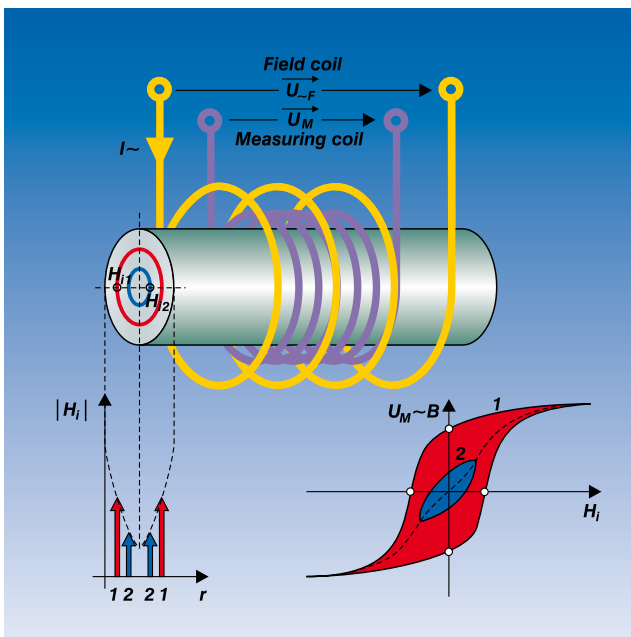

▲ Magneto-inductive testing determines the significant material properties from the electric and magnetic properties of ferromagnetic components.

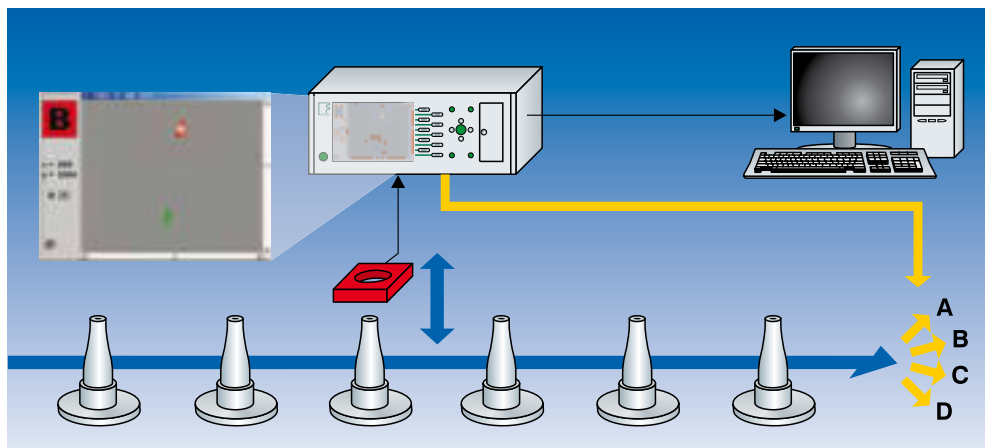

▲ In modern production lines, magneto-inductive testing for material properties works fully automatically.

MULTI-FREQUENCY TESTING AND HIGHER HARMONIC EVALUATION



▲ At multi-frequency testing the results of up to a maximum of 24 single frequencies with the corresponding separation indices are shown in an overview.

Multi-frequency testing

Serial multi-frequency testing works with several different testing frequencies. The individual items of test information are subsequently determined with the defined frequency settings in a single testing procedure, which is automatically controlled by the testing system. The combination of several frequencies and magnetisation field intensities makes it possible to evaluate different material properties at the same time and/or to selectively suppress disturbance variables. As the tests take place in series, the overall testing time is determined by the number of set frequencies.

Higher harmonic evaluation

The strong, linear power amplifier of the MAGNATEST devices is the basis for the higher harmonic evaluation. In high energy modus the components inside the MAGNATEST test coil are penetrated by a strong alternating magnetic field. The alternating magnetisation of ferromagnetic parts is characterised by the so called “hysteresis curve”, which is a very sensitive indicator for changes of material structure or grain size. Consequently by means of “high energy” eddy current testing it is possible to evaluate the hysteresis curve of the test part which is represented in the MAGNATEST devices by higher harmonics (odd multiple of the transmission frequency). The principle of higher harmonic evaluation with many receiving frequencies (for each transmission frequency) has to be distinguished from a simple multi-frequency testing with several transmission frequencies. As a consequence of the hysteresis curve evaluation, the higher harmonic evaluation guarantees – in difference to the standard single- or multi-frequency eddy current testing – a strong robustness against disturbing influences as for example varying part temperature or mechanical misalignments of test part position in test coil, as well there is no calibration required for new charges/batches. The higher harmonic evaluation assures the long term stability of the test results. The advantages of the MAGNATEST devices in modus “Higher harmonic evaluation” for different applications is confirmed in many production lines.

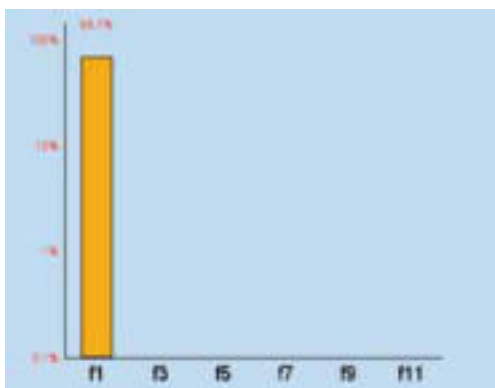

▲ Spectrum of the received signal with evaluation of the fundamental wave or multi-frequency testing.

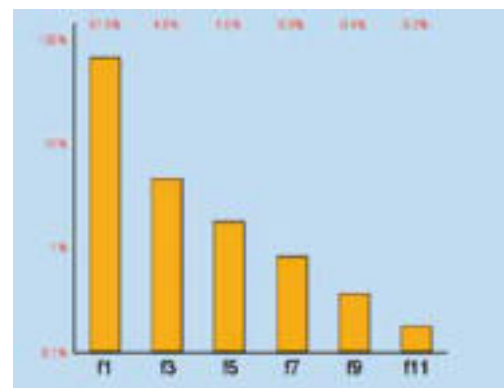

▲ Spectrum of the received signal with the high energy Higher harmonic evaluation.

CRACK DETECTION WITH TEST ELECTRONICS AND



STATOGRAPH ECM

Eddy current test device in modular design, for simple standard applications. The test classifications of the STATOGRAPH ECM are “good”/ “bad”. Inexpensive basic test device, fully capable of line operation, with modern microcontroller technology and PC interface. Can be extended to form multi-channel testing systems. Optionally expandable with the operating and visualization software eddyAssist. At STATOGRAPH ECM CE the test module STATOGRAPH ECM and the operating software eddyAssist are bundled to a compact unit.



STATOGRAPH DS

Processor-controlled eddy current testing system for fully automated single and multiple channel crack detection. Suitable for simultaneous testing of various areas. Detailed documentation of test results. Interface for connection to a host quality management system. Digital system technology for automatic, high-resolution, multi-channel online defect testing/crack detection, as well as individual setting of the test channels. Clearance compensation and group sorting. Menu-guided operation based on WINDOWS[®], assisted by an application assistant. Very easy to use thanks to guided instrument settings and automated comparison procedures.

STATOGRAPH[®]



The variable ECM multi-channel solution provides a user-specific configuration in an industry-compatible 19" instrument rack. The modular design provides capacity for extension, e.g. for magneto-inductive testing. Optimised protection of system components thanks to standard-fitted cooler with a closed cooling circuit.

STATOGRAPH CI

The eddy current testing system STATOGRAPH CI is either equipped with one or two independent test channels with a maximum test frequency of 3 MHz. Already the basic model has the clearance function integrated and permits an electronic online readjustment of the test sensitivity at clearance variation between test piece surface and eddy current sensor. The integration of the menu guided „Setting assistant“ for the automated determination of application specific test parameters. The user defines a preselection of parameters, then an automatic setting cycle is following.



SENSOR SYSTEMS

Testing probes for crack detection

Fixed and rotary eddy current probes are used for crack detection on components. A comprehensive range of standard sensors is available for the most varied testing jobs. This way it is possible to design inexpensive solutions for typical testing functions.



Special sensors

If a testing job requires special solutions, FOERSTER designs and manufactures individual customised sensors. The range extends from adapting existing standard sensors through to completely rebuilding the sensor geometry. The picture shows probe elements adapted to specific tasks with angled heads or for extremely narrow access channels and excentric parts like cams or camshafts.



Rotating sensor systems

If the task requires it, testing can be carried out with rotating sensors and a stationary specimen. Various rotating heads and rotary probes are available for this purpose. In this case, the testing unit consists of a drive unit and a rotary probe tip. Testing with rotating sensor systems allows for high throughput performance while keeping the handling effort low.



MATERIAL TESTING WITH TEST ELECTRONICS AND

MAGNATEST® ECM

Test device in modular design, for simple standard applications such as hardness testing or material identification. For mono-frequency testing with group analysis. PC interface. Can be extended with eddyAssist operating and visualization software. With MAGNATEST ECM CE the test module MAGNATEST ECM and the operating software eddyAssist are bundled in a compact unit. Especially if visualization of the test results is essential the MAGNATEST ECM CE is a suitable alternative. MAGNATEST ECM as well as MAGNATEST ECM CE can be extended with an external power amplifier.



▲ The MAGNATEST ECM is a basic module which can be used in line operation for simple testing tasks.

MAGNATEST D

The processor-controlled magneto-inductive compact test device is designed for fully automated testing of material properties in single coil absolute mode. In addition to the fundamental wave, the harmonic components of the test signal can also be utilised. Evaluation takes place as a group analysis in up to six sorting categories, while the shape and size of the tolerance ranges can be individually adjusted. When testing in serial mode, a maximum of 24 stored and individually defined parameter sets can be used. Within the program structure the menu guided FOERSTER setting assistant is integrated.

The MAGNATEST D can be supplemented with one or more frequencies using a multiplexer for electronic switchover in multi-coil operation. Comprehensive documentation options for test results, such as test item statistics, bar chart visualisation and test data export. An interface for connecting host quality management systems facilitates networking and comprehensive statistics.



▲ The MAGNATEST D is the most frequently used computer-assisted test device in the automobile industry world-wide.



SENSOR SYSTEMS

Coils for testing of material properties

According to the test arrangement, the sensors for testing material properties are designed as coils or as probes. The various MAGNATEST test devices are provided with a comprehensive range of standard testing coils with round and rectangular cross sections, as well as standard testing probes.



Coils

The clearance of the opening with through-type coils depends on the items to be tested. Depending on the shape and cross section of the test item, the coils can be changed, thus making it simple to convert the test systems for other functions.

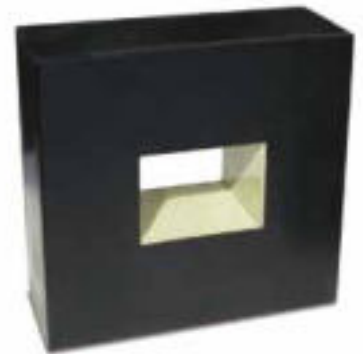

Probes

Wherever encircling coils can not be used, probes which are adapted to the testing task are employed. This makes it possible to carry out testing in positions which are difficult to access or to determine the local characteristics of the micro-structure.



ASSISTANTS AND REGRESSION

Capability of separation

The capability of separation at magneto-inductive testing depends on the test parameters, especially the test frequency and the magnetic field strength. The application assistant supports to get the optimum combination based on the preselected parameters and so reduces the amount of work significantly.

- Step by step operator guidance for the optimization process
- Calculation of the separation after collecting at least five good parts
- Display of the optimum test settings after testing the part to be separated
- Activation of the determined test parameters by the operator for the routine test

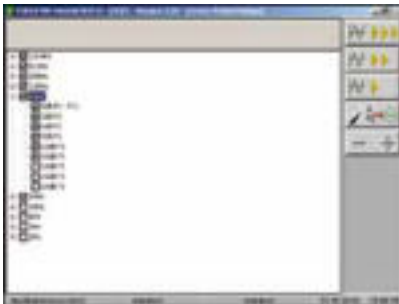

▲ Display of the possible parameter combinations at test systems MAGNATEST D and MAGNATEST ECM Compact Edition.

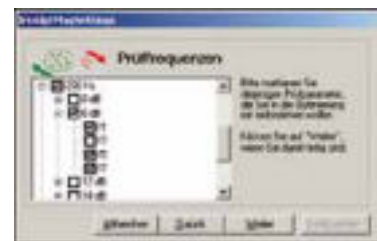

System	Stärke	Frequenz	Ergebnis	Bestwert	Streuung	
120Hz	640	71	4,98	5,38	9,11	22,11
120Hz	640	71	4,95	5,38	9,11	22,11
120Hz	640	71	26,13	4,95	26,41	21,98
120Hz	640	71	26,13	4,95	26,41	22,18
120Hz	640	71	3,98	4,42	2,30	22,12
120Hz	640	71	26,68	2,36	26,68	26,68
120Hz	640	71	4,17	4,42	5,40	26,68
120Hz	640	71	4,21	4,25	4,21	26,71

▲ If a separation of the both conditions has been possible the set of parameters with the best separation (highest separation index) is already marked. The capability of separation depends on the type of the tolerance field so the value is displayed for all possible test categories.



▲ The functionality of the assistant is also available at the test systems STATOGRAPH ECM Compact Edition and STATOGRAPH CI. Beside the dynamic determination of the best test settings it is also possible to use a menu guided assistant function for optimization at the clearance compensation.

CLARIS

The results of the magneto-inductive testing depend on the electric and magnetic properties of the test piece. This factor is linked in close relationship with the technological property of the material. The nearly linear correlation between the test data of MAGNATEST D and the technological properties of the test pieces permits after a calibration to determine a technological value based on a linear regression calculation. Beside the two dimensional eddy current value the determined technological value is stored additionally. In the next step the software calculates the regression line. The quality measure of this correlation is defined as correlation factor with a numerical value or a percentage. The higher the value the more precise the parameter can be determined. Subsequently the technological value of unknown parts can be calculated with the eddy current values. The field of application needs to be verified in any case.

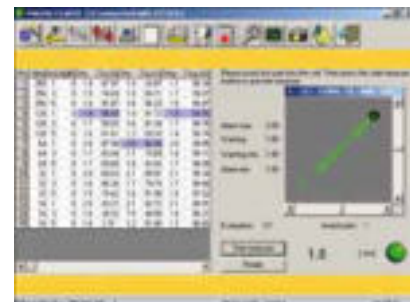

▲ Test result display with MagnaClaris.

TESTING CONCEPTS

Testing stations for multi-shift operation

FOERSTER testing stations are robust and provide maximum precision at the same time. These features guarantee high operational reliability – also during continuous multi-shift operation. FOERSTER testing stations are highly flexible and can be used as complete systems or in different extension stages depending on your requirements. In accordance with your specific task, the desired degree of automation is already taken into account during the conception. The integration of the test systems can optionally take place either directly in the production line between different machining steps, or on typical process stages such as the final inspection or goods receipt and output.



▲ Fully automated three-channel crack test system (Roto-Scan) with manual loading of the test piece buffer or line integration.



▲ Manual system for testing of microstructure with automatic test start (internal trigger) and two-way-sorting.

Fully automated crack test system (Roto-Push) with conveyor. ▶



PISTON RODS/PISTON PINS ROTO-PUSH



STATOGRAPH DS

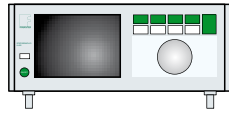

STATOGRAPH CI

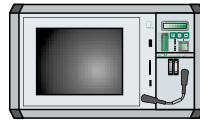

STATOGRAPH ECM CE

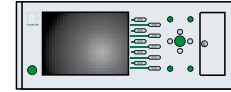

MAGNATEST D

- Fully automated 100 % crack detection in continuous operation
- Extremely high test throughput, as parts do not need to be separated
- Automatic sorting into two groups, „good“ and „bad“
- Testing of cylindrical components from 8 mm to 65 mm
- The ratio between length and diameter of the component must be above five
- Documentation of the results



▲ Detailed view of the rotating head including transfer system. In the case of the modern testing solutions with a rotating head used in practice, the batches of cylindrical workpieces pass through the rotating unit with eddy current probes in quick succession. These probes perform full-coverage scanning of the outer shell surface of the cylindrical workpieces

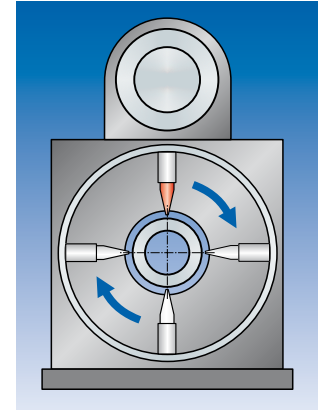

▲ The high throughput of the rotating testing systems results both from the high rotating speed and the continuous stream of parts.



◀ Manufacturing integrated testing station for inspecting the outer shell surface of cylindrical components for cracks. This efficient testing solution particularly stands out due to its high throughput performance.



BEARINGS ROTO-SCAN

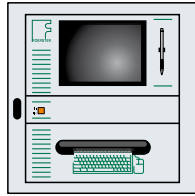

STATOGRAPH DS

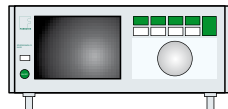

STATOGRAPH CI



STATOGRAPH ECM CE

- Fully automated 100 % crack detection
- Testing of the inner and outer contours with two linear eddy current probes
- Test throughput approximately 1,000 specimens per hour
- Extremely short setup times thanks to extensive elimination of interchangeable parts
- Testing programs supplied for specific components
- Automatic sorting into two groups, „good“ and „bad“
- Interface for connection to a host quality management system
- Documentation of the test results

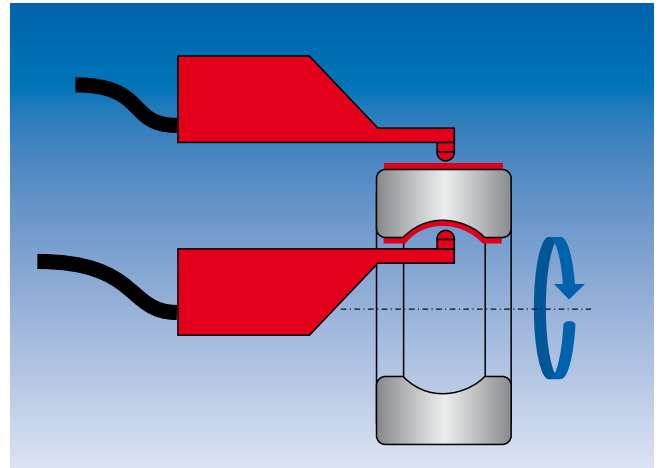

- ▲ The testing mechanics are designed for extremely gentle handling of specimens. The testing probes perform full-coverage scanning of the inner and outer contours while the specimen simultaneously rotates.



- ▲ The testing mechanism is designed to be extremely compact and maintenance-friendly. Operation takes place via the integrated terminal.

A four-channel test system for testing on inner and outer diameter as well as both face sides of non-profiled bearings.





VALVES / VALVE TAPPETS



STATOGRAPH DS

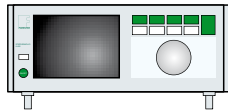

STATOGRAPH CI

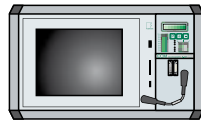

STATOGRAPH ECM CE

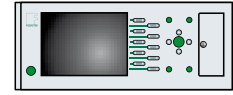

MAGNATEST D

- Fully automated, combined crack detection and hardness testing
- 100 % testing
- Testing of critical zones for surface cracks with stationary and linear eddy current probes
- Testing of hardness penetration with MAGNATEST encircling coil
- Test throughput approximately 2,000 specimens per hour, depending on size and shape
- Automated sorting into three quality groups, „good“, „crack“ and „hardness defect“
- Documentation of the results



- ▲ Inside the high performance core mechanism in testing station 1, the linear probe scans the shell surface of the car engine tappets, while a stationary probe (hidden) simultaneously scans the chamfer. In testing station 2 (not shown), a rotating probe scans the face surface.

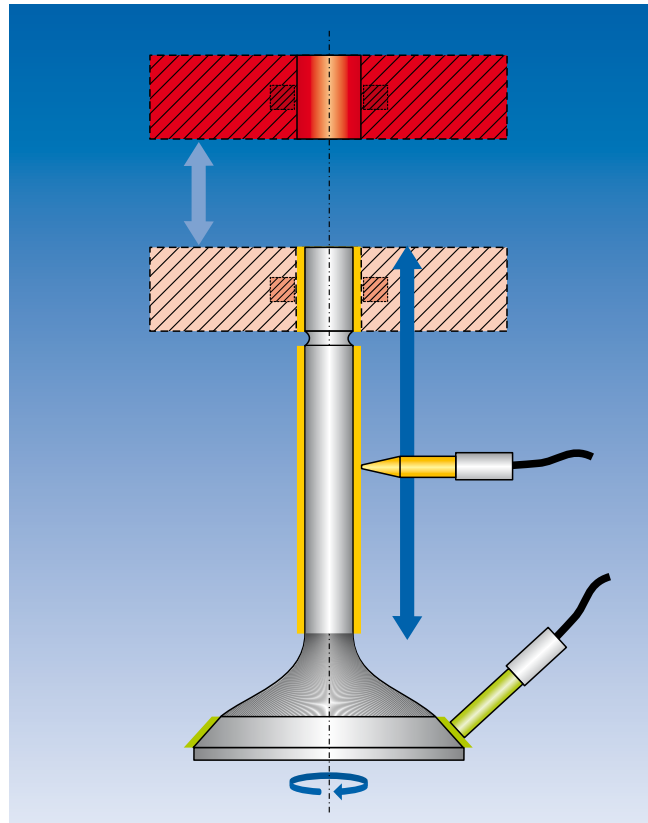

- ▲ During combined crack detection and hardness testing, the crack detection probes scan the critical parts of the components. For this purpose, the probes can be adjusted to the respective testing area and can either be traversed or can be stationary. For non-destructive inspection of the heat treatment condition, an additional encircling testing coil is used on the valve stem.

VALVE SEAT RINGS

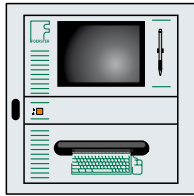

STATOGRAPH DS

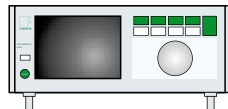

STATOGRAPH CI

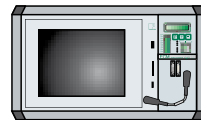

STATOGRAPH ECM CE

- Fully automated 100 % crack detection
- Simultaneous testing of the outer shell surface and the inner contour of the rotating rings with two linear eddy current probes
- Test throughput up to 1,500 specimen per hour
- The testing station can be used for different seat ring types
- Optional numerical control for complex geometry
- Automated sorting into two quality groups, „good“ and „bad“
- Documentation of the results

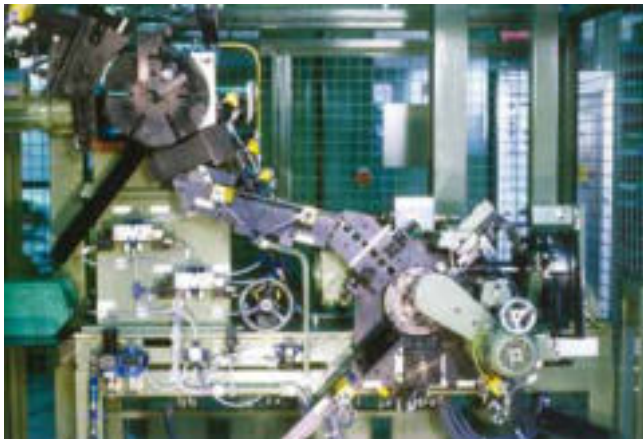

- ▲ The valve seat rings are passed through the feeder system, the separation mechanism, the position control and the reversing stations into the crack testing station.

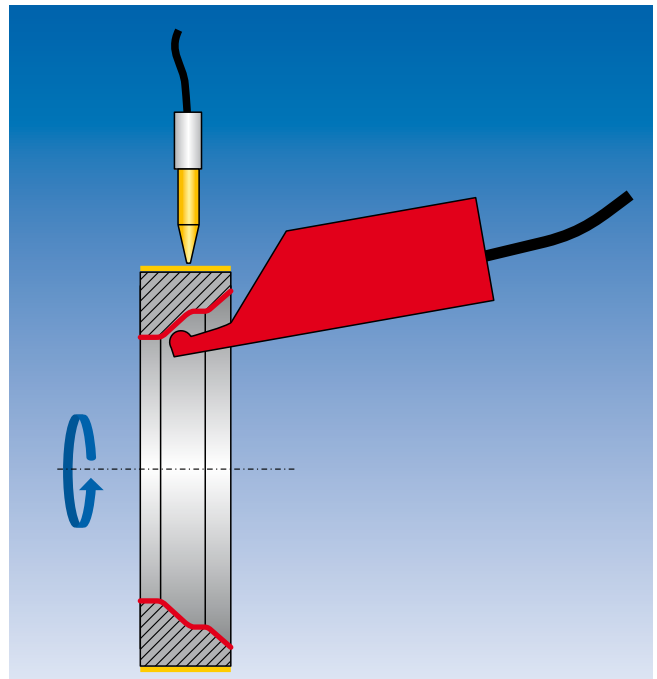

- ▲ Probe positioning for simultaneous crack detection on the inner and outer contours. Differences in sensitivity due to fluctuations in the distance between the probe and the material surface are automatically eliminated by a built-in clearance compensation system. The crack detection sensitivity therefore remains constant at all locations.



- ◀ Testing cell for simultaneous testing of inner and outer contours during uniform rotation.



CYLINDER BORES



STATOGRAPH DS

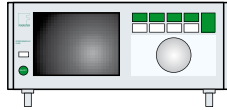

STATOGRAPH CI

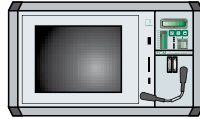

STATOGRAPH ECM CE

- Automated testing of cylinder bores in aluminium engine blocks
- Scanning of the internal surface with rotating, longitudinally guided eddy current sensor
- Testing for open cracks and pores, as well as for imperfections just beneath the material surface
- Test throughput approximately 120 bores per hour
- Evaluation software optimised for the specific testing job
- Automated classification of test results into two quality groups, „good“ and „bad“
- Documentation of the results

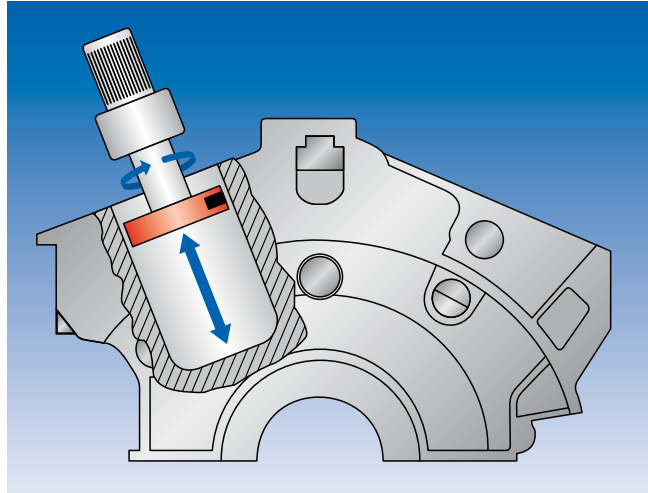

▲ The cylinder bores in the engine blocks are automatically tested for imperfections using handling systems customised for the testing function. Thanks to its excellent resolution, the eddy current test with special rotary eddy current sensor also reveals imperfections in the aluminium block which are hidden below the material surface besides those which are unconcealed on the surface.



▲ In Nicasil cylinder linings, it must be checked whether the 60 to 80 μm thick coating applied to the cylinder surface has sufficient adhesion to the basic material. Cracks, pores and bonding defects are reliably traced by helical scanning of the contact surface with a special rotary eddy current sensor.

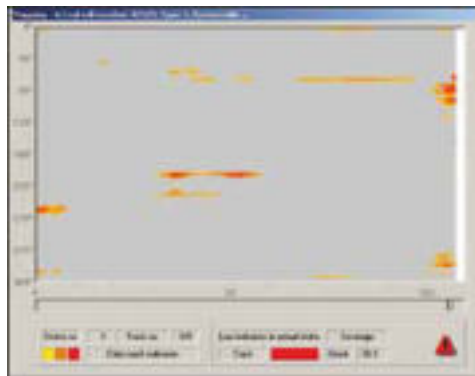

▲ Mapping of a scanned cylinder lining with multiple discontinuities varying in characteristic and position.



CAMSHAFTS

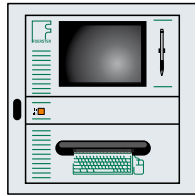

STATOGRAPH DS

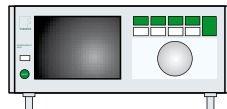

STATOGRAPH CI

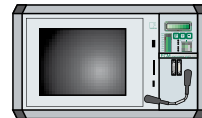

STATOGRAPH ECM CE

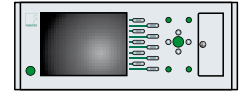

MAGNATEST D

Cam

- Fully automated 100 % testing of microstructure, geometry and contour characteristics, as well as crack detection on forged or sintered cams
- Test throughput up to 900 specimens per hour
- Highly consistent sensitivity during crack detection thanks to probe concept optimised for cam geometry
- Several testing zones during crack detection
- Short changeover times to other cam types
- Documentation of the results



▲ Crack detection on individual cams with two testing probes on the contact surface and one testing probe on each face side.



▲ Microstructure testing is additionally carried out on a separate station with an encircling MAGNATEST testing coil.

Camshafts

- Fully automated 100 % testing for hardening cracks
- Scanning the entire cam contact surfaces and all bearing seat surfaces with rotating camshaft
- Reliable crack detection on the full circumference of the cam and bearing surfaces
- Simultaneous testing with 8 MECA-PROBE probes
- Expandable with microstructure testing and assignment of results into zones
- Automatic bad part scenario on detection of a hardening crack
- Documentation of the results



▲ MECA-PROBE for testing of excentric parts like individual cams or camshafts with a flat or abrupt contour.



TURNED PARTS



STATOGRAPH DS

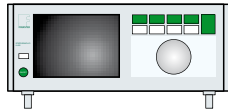

STATOGRAPH CI

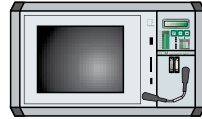

STATOGRAPH ECM CE

- Semiautomatic defect detection on turned parts
- The operator has to place the parts into the fixture.
- Testing and sorting will be done automatically
- 2-channel solution for parallel testing of two parts
- Defect detection in one selective test zone
- Diameter of the parts under test: 7 - 20 mm
- High throughput: up to 1,500 parts / hour
- Visualisation of the test results via eddyAssist
- Easy to operate due to quick changeable part fixtures
- Designed as ergonomically hand work-place



- ▲ Test mechanism integrated in an ergonomically designed hand work-place.

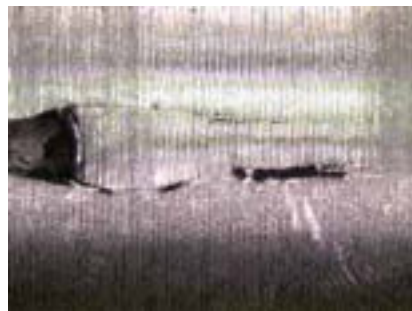

- ▲ Natural cracks in turned parts.

AXLE PIVOTS

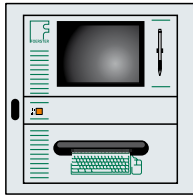
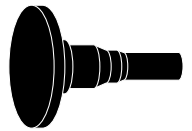

STATOGRAPH DS

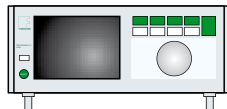

STATOGRAPH CI

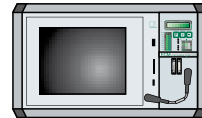

STATOGRAPH ECM CE

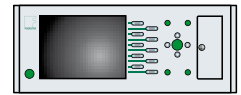

MAGNATEST D

- Fully automated testing for material identification and heat treatment conditions
- 100 % testing with encircling MAGNATEST testing coil
- Test throughput approximately 360 specimens per hour
- Automatic sorting into two quality groups, „good“ and „bad“
- Optional crack detection across the entire surface or in selected zones
- Modular test electronics and handling for crack detection
- Interface for connection to a host quality management system
- Documentation of the results



▲ In several successive stations, each pivot blank is tested for surface defects and heat treatment condition by means of eddy current.

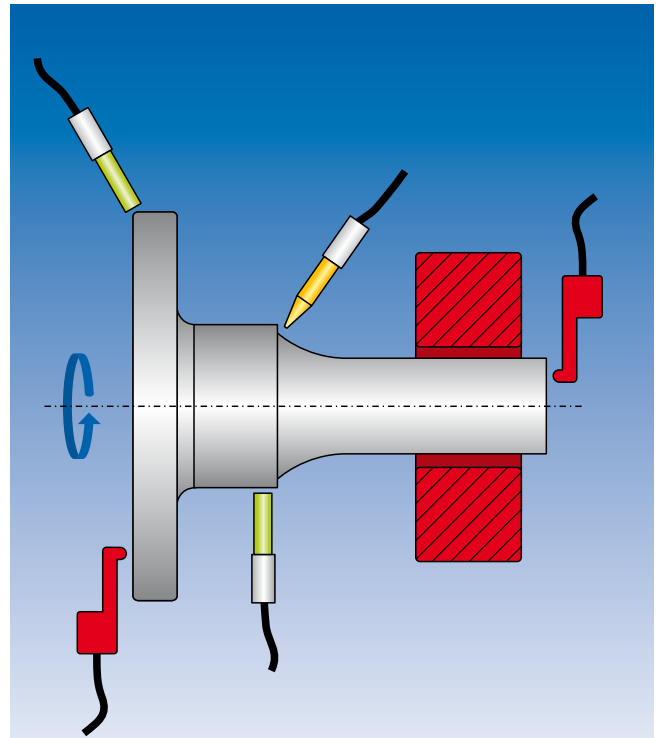

▲ Example for crack detection and microstructure testing of axle pivots. The parts are first set in rotation for crack detection on critical zones. Testing takes place with stationary eddy current probes on the entire component circumference. For inspecting the heat treatment condition, an additional MAGNATEST testing coil is positioned in the pivot area.

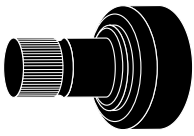

CV - JOINTS

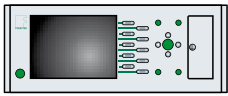

MAGNATEST D



Multiplexer

- Fully automated 100 % hardness testing in the production line
- Testing by means of encircling special coil with three testing levels and electronic switchover (multiplexer)
- Result evaluation is carried out separately for each of the three testing levels
- Test throughput approximately 240 specimens per hour
- Automatic system stop on detection of an insufficiently hardened part
- Interface for connection to a host quality management system
- Documentation of the results



MAGNATEST D



- ▲ With the MAGNATEST D multiplexer, defectively hardened CV-Joints can be reliably detected, while defect causes, e.g. within the hardening process, can be targeted and corrected.



- ▲ Test piece diameter optimized cylindrical inner test probe for reproducible testing with higher harmonic evaluation.



- ▲ Test piece contour optimized inner test probe for reproducible testing with higher harmonic evaluation.



BRAKE DISCS



STATOGRAPH DS

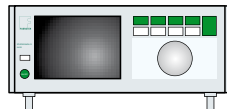

STATOGRAPH CI

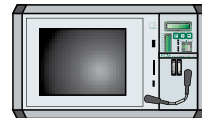

STATOGRAPH ECM CE

- Fully automated 100 % crack detection in the production line
- Simultaneous testing of defined zones of the braking surface and bolting surface both on the outside and inside of the brake disc
- Testing of the rotating brake disc with traversable eddy current probes
- Test throughput approximately 240 specimens per hour
- Testing station can be re-equipped for different brake disc types
- Optional detection of relevant geometrical data
- Automatic sorting into two groups, „good“ and „bad“
- Documentation of the results

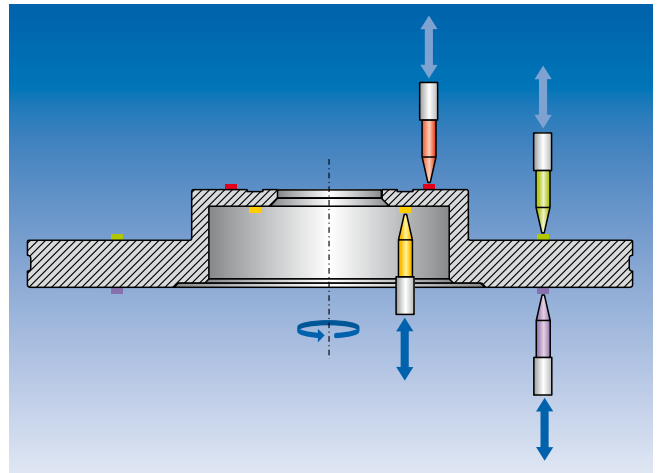

▲ In this case, the testing concept was adapted to the requirements of the testing job so that four separate probes scan the relevant testing zones of the brake disc. The use of several test modules has resulted in a multi-channel solution working at a high clock speed.



▲ Thanks to a swivel-mounted operating panel, the compact testing cell for crack detection on brake discs is very user-friendly.



◀ Traversing unit with probe holder and eddy current probes for testing the outer bolting and braking surfaces.



GEARBOX SHAFTS



STATOGRAPH DS

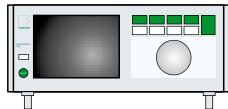

STATOGRAPH CI

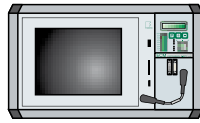

STATOGRAPH ECM CE

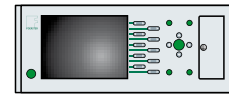

MAGNATEST D

- Fully automated, combined 100 % crack detection and heat treatment testing
- Testing of heat treatment condition with MAGNATEST testing coil
- Test throughput approximately 360 shafts per hour
- Simultaneous testing of the critical zones for cracks with one contour-tracking and two stationary eddy current probes
- Automatic sorting according to the respective test result, into „good“ and „bad“
- Documentation of the results

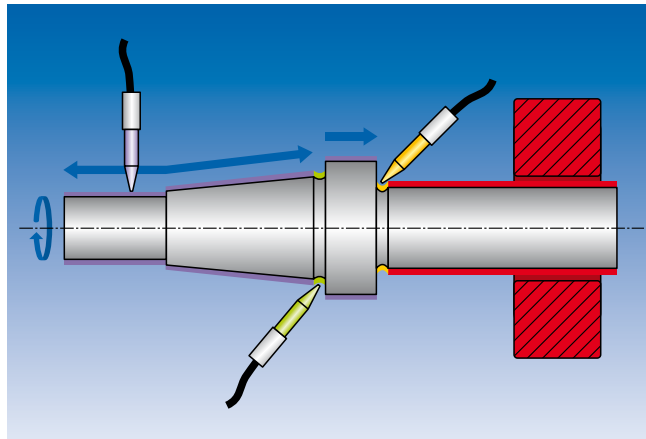

▲ Critical material zones such as bearing seats and diameter transitions are checked for material cracks by the 100 % eddy current test.

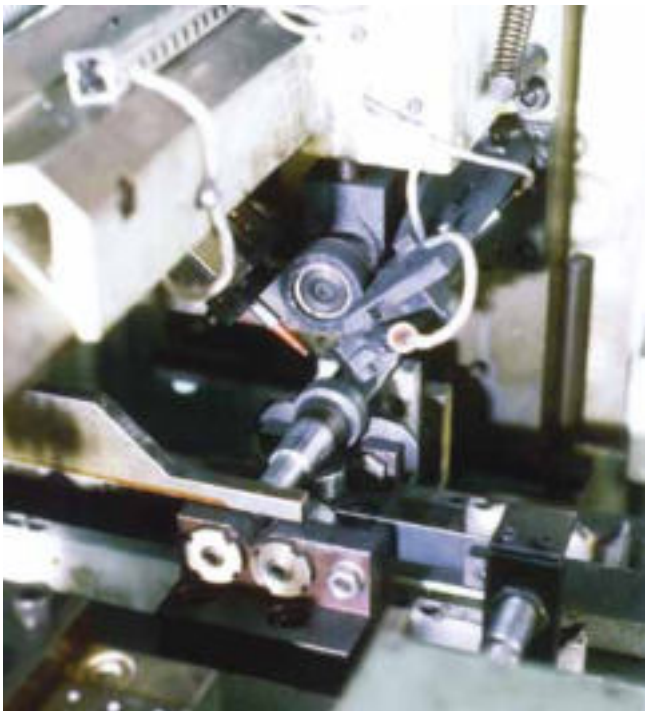

▲ An eddy current probe scans the surface of the part during crack detection. Two further testing probes test the undercuts on critical cross-section transitions of the specimen. An additional MAGNATEST testing coil is positioned on the end of the shaft to test the heat treatment condition.



WHEEL HUBS



STATOGRAPH DS

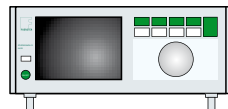

STATOGRAPH CI

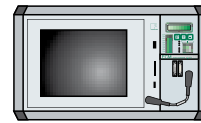

STATOGRAPH ECM CE

- Fully automated 100 % crack detection
- Testing of the entire outer contour with numerically controlled eddy current probes
- Combined use of traversable and rotating eddy current probes
- Tandem testing system with two testing stations arranged in parallel
- Test throughput approximately 240 specimens per hour
- Automatic sorting into two groups („good“ and „bad“) with optional indication of faulty testing zone
- Documentation of the results

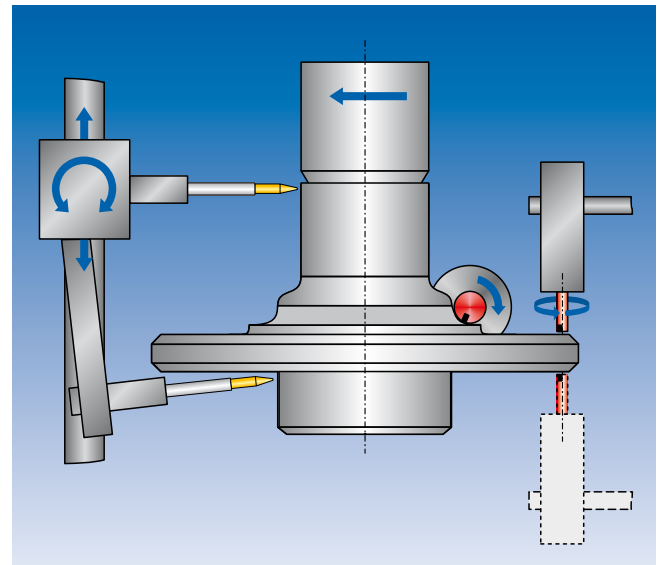

- ▲ Components with a complex geometry such as these wheel hubs are also efficiently tested with eddy current sensors and programs adapted to suit the task.



- ▲ To optimise the cycle time, manufacturing integrated 100 % testing of wheel hubs (see illustration) takes place in a tandem test station with two parallel workpiece holders. Receiving station two is loaded or unloaded while the wheel hub is tested in receiving station one.



BALL PINS

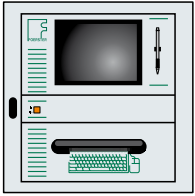

STATOGRAPH DS

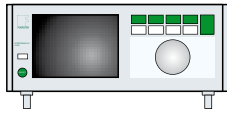

STATOGRAPH CI

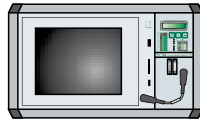

STATOGRAPH ECM CE

- 100 % crack detection on ball pins/tie rods
- Simultaneous testing of several zones with one or more eddy current probes
- Test throughput approximately 600 specimens per hour
- Modular system concept for optimal adjustment to the respective set of requirements
- Automatic sorting into two groups, „good“ and „bad“
- Optional graphical display of results on the system monitor
- Documentation of the results

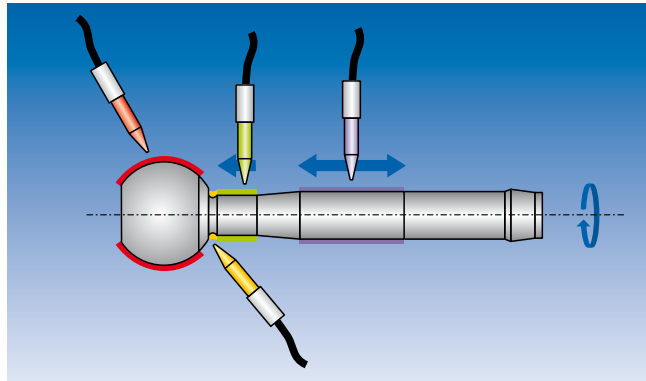

▲ This illustration shows four eddy current probes performing a 100 % scan for material cracks on the critical areas of the ball pin and the tie rod. The multi-channel feature increases the clock speed.



Compact testing system for ball pins with a numerically controlled eddy current probe for scanning the component contour. Due to the design with two testing cavities, the actual eddy current test is separate from the loading and unloading processes. This additionally increases the throughput performance of the system.



Detailed view:
Numerically controlled
traversing unit with
eddy current probe. ▲

GEAR RACKS

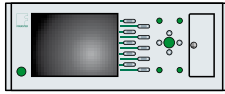

MAGNATEST D

- Partially automated spot-check testing for hardness penetration
- Testing with encircling MAGNATEST test coil
- Automatic test activation after reaching the respective testing position with electronic monitoring of positioning
- Separate display of hardness penetration for each testing location
- Type switch-over and setting of testing positions by means of exchangeable index roller
- Interface for connection to a host quality management system
- Documentation of the test results

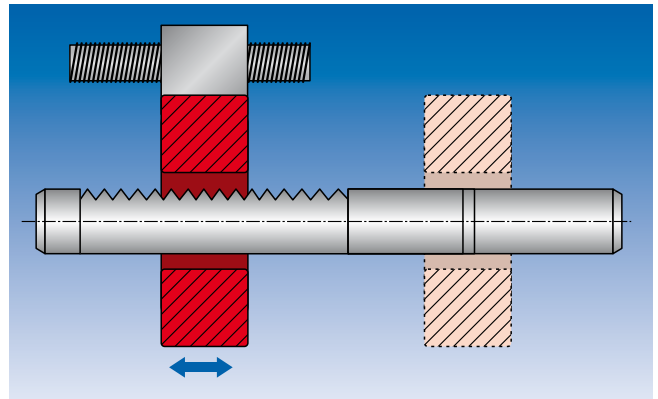

- ▲ Principle of testing process for hardness testing on several testing locations on shafts, axles or similar components with encircling MAGNATEST testing coil.



- ▲ Manual testing system for non-destructive inspection of long components, e.g. drive shafts, gear racks and the like. For testing, the parts are manually inserted and clamped. The testing coil is subsequently moved to the preadjusted testing positions and the testing procedure is automatically carried out. The exact positioning is monitored electronically, and the test results are processed and displayed to the specific requirements of the user.



ROLLS



STATOGRAPH DS

- Fully automated 100 % testing of the roll surface during and /or after the grinding process
- Integration into existing roll grinding machines
- Simultaneous testing for surface defects and hardness
- Testing of work and back-up rolls
- User-specific processing and documentation of the test results (mapping)
- Interface for connection to a host quality management system
- Documentation of the roll history

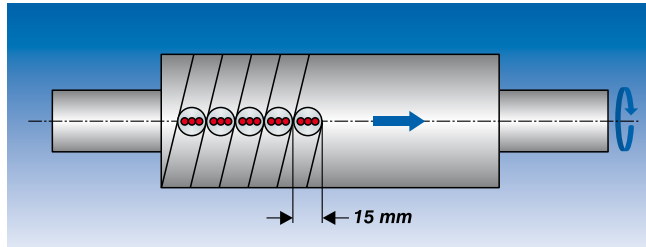

▲ Helical scanning of the roll surface with clearance-controlled special test probe.



▲ Roll grinding machine within roll-shop with integrated eddy current testing.

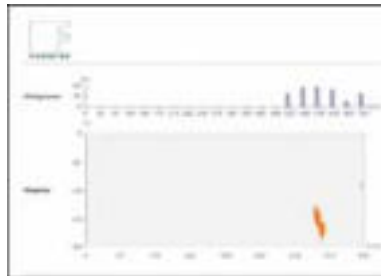

▲ Test protocol with information about defect position and value of defect.

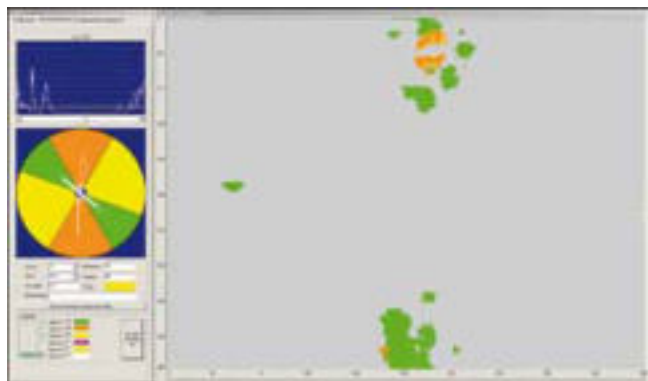

▲ Graphic processing of results for a typical defect pattern on used work and back-up rolls.

DRIVE SHAFTS



STATOGRAPH DS

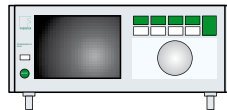

STATOGRAPH CI

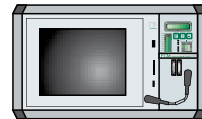

STATOGRAPH ECM CE

- Fully automated 100 % crack detection of the entire outer shell surface
- Numerically controlled contour tracking of eddy current probes (X- and Y- axes)
- Test throughput approximately 500 specimens per hour in triple cycle
- Torque up to 2,000 rpm
- Minor conversion effort due to supplied testing programmes
- Automatic sorting into two groups, „good“ and „bad“
- Documentation of results including test item statistics

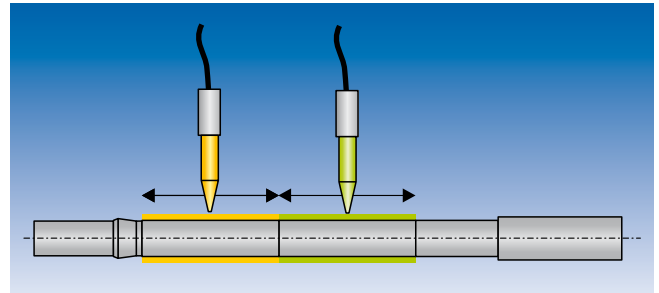

▲ Schematic illustration of testing process. The probes are tracked across the entire testing length while maintaining a constant clearance to the surface.



◀ Arrangement of the three testing heads including the eddy current probes, which simultaneously scan the drive shafts to be tested.

► Compact testing cell with manual loading and unloading. Operation is simple and clearly laid out thanks to the supplied testing programmes.



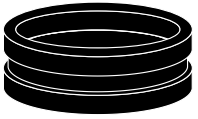

VALVE SEATS

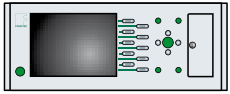

MAGNATEST D

- Fully automated 100 % hardness testing in double cycle
- Testing with encircling MAGNATEST coil for different heat treatment conditions
- Test throughput approximately 480 specimens per hour
- Inspection of geometry and dimensional accuracy in further sections in a compact testing station
- Automatic sorting into two groups, „good“ and „bad“
- Documentation of the results

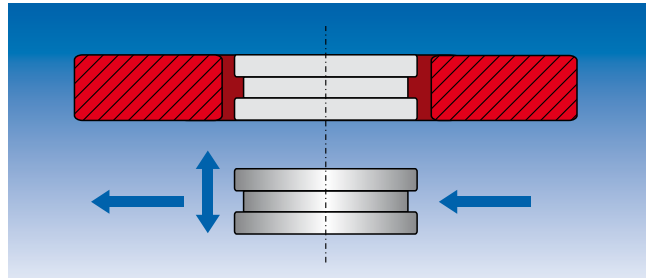

- ▲ Schematic illustration of testing process during hardness testing on valve seats. The valve seat is removed from the transfer system, positioned in the coil and transported further along after the testing procedure.



- ▲ Accurate feed and positioning of the valve seats in the MAGNATEST test coils for hardness testing in double cycle by means of a plastic mandrel and bedstop for high throughput performance.

CERTIFICATES

Modern eddy current testing gives you competitive advantages

Competence and know-how from decades of hands-on experience within the FOERSTER Group are your guarantee for state-of-the-art testing technologies and testing systems for quality control in automotive manufacturing. The constant monitoring of processes and products ensures the quality of each individual component and every service. We offer reliable advice as well as technical service and seminars or workshops which confer proficiency in application.





Institut Dr. Foerster GmbH & Co. KG
Division CT Component Testing
Joseph-von-Fraunhofer-Str. 15
44227 Dortmund
Germany
Phone +49 231 975049-0
Fax +49 231 975049-8
E-Mail: ct@foerstergroup.de
www.foerstergroup.de