

PARKER

AC YOKE INSPECTION AT REMOTE WORKSITES WITH NO OUTSIDE POWER SOURCE, NO GENERATOR...WITH THE *NEW* PARKER BAC310 PORTABLE, BATTERY OPERATED AC POWER SUPPLY...



- STAND ALONE BATTERY POWERED AC POWER SUPPLY – FOR AC YOKES
- ON THE SPOT AC POWER – INDEPENDENT OF ANY OUTSIDE POWER SOURCE
- TOTALLY PORTABLE FOR SHOP OR FIELD APPLICATIONS
- PROVIDES FOR COMPLIANCE WITH APPLICABLE SPECIFICATIONS



02 - 88503755

INSTRUMENT DESCRIPTION: The BAC310 battery operated Inverter/Power Supply is a totally portable, stand alone, 110VAC power source. It will operate any of the Parker or other A.C. Yokes. In addition, the Parker B310PDC (12V) battery operated Contour Probe will operate from the BAC310 by direct connection to the female battery plug.

The BAC310 operates independently from any outside power source. Power is derived from the internal 12VDC battery, which is inverted to 110VAC output through the inverter circuitry. A separate battery charger is provided for overnight charging of the battery. The entire unit is contained within a heavy duty steel case 11-1/2"H x 7-1/2"W x 5-1/2"D and weighs only 28 pounds. The unit may be used in any shop or field application and is ideal in areas where normal A.C. line power is not available or where outside power sources may present a safety concern.

Plug any of the Parker A.C. Contour Probes (yokes) in to the standard BAC310 110V outlet. Be sure that the 12V battery is fully charged. There is nothing else to do. The Contour Probes will function as they would normally from any A.C. power source. Follow operating instructions and procedures for normal A.C. Yoke inspection. All Parker Contour Probes exceed applicable Magnetic Particle inspection requirements.

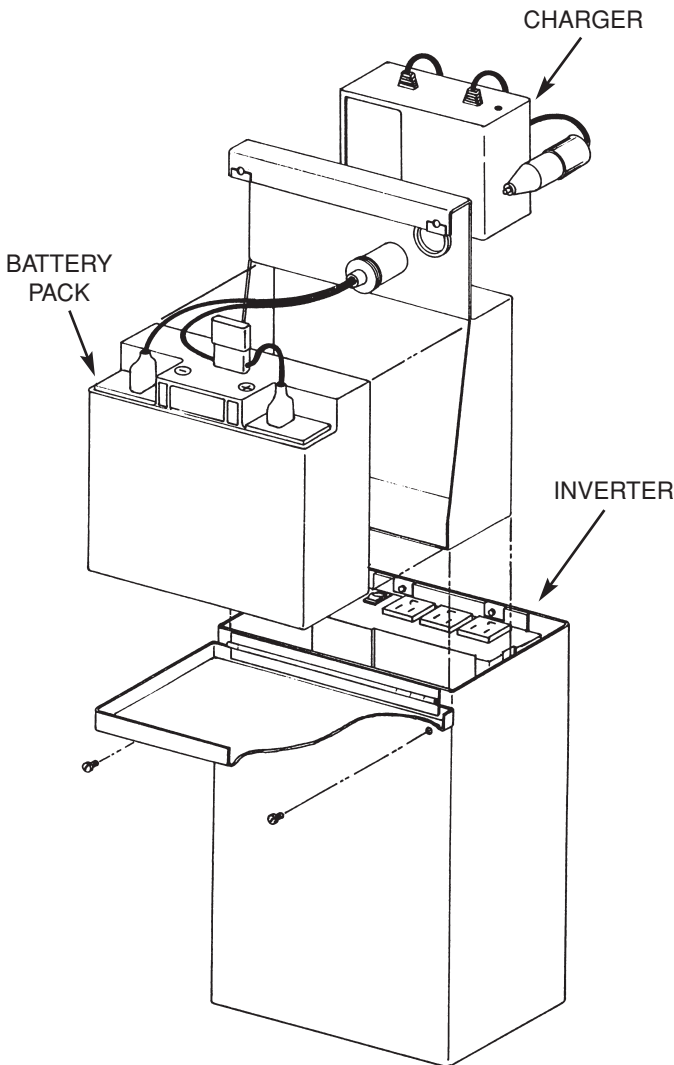

BAC310 AC POWER SUPPLY ASSEMBLY	
DEDICATED USE.....	AC YOKES
CURRENT DRAW.....	7.5A (B310)
APPROXIMATE RUNNING TIME.....	2 HOURS
TOTAL WEIGHT	12.7 KG

BAC310-600 INVERTER	
MAXIMUM CONTINUOUS POWER	600 WATTS
SURGE CAPACITY (PEAK POWER)	1200 WATTS
MAXIMUM EFFICIENCY	APPROX. 90%
NO LOAD CURRENT DRAW	0.8A
LOW VOLTAGE SHUTDOWN ACTIVATION ..	10.0 VOLTS
LOW VOLTAGE ALARM ACTIVATION.....	10.6VOLTS
WAVE FORM	MODIFIED SINE WAVE
FUSE	THREE 25 AMP (SPADE TYPE)
WEIGHT	1.9 KG

BP20 BATTERY PACK	
TYPE	RECHARGEABLE SEALED LEAD ACID
RATING.....	12V. 20Ah/20 HR
FUSE	20A INLINE SPADE TYPE
WEIGHT	6.5 KG

BC310 CHARGER - Australian Version	
TYPE	COLOURED INDICATOR
INPUT	240VAC
OUTPUT	12VDC, 1.5A
WEIGHT	0.87KG

